





Repubblica di San Marino
Autorità per l'Omologazione
Republic of San Marino
Authority for Homologation

Via Consiglio dei Sessanta, 99
47891 Dogana - Repubblica di San Marino

Comunicazione
Communication

	Concernente ^{2/} Concerning ^{2/}	Il rilascio dell'omologazione Approval granted L'estensione dell'omologazione Approval extended Il rifiuto dell'omologazione Approval refused La revoca dell'omologazione Approval withdrawn La cessazione definitiva della produzione Production definitively discontinued
--	---	--

Of a type of an Electronic rear-view mirror, pursuant to Regulation No. 46.05

Omologazione N. Approval No.	E57*46R05/00*0131	Estensione N. Extension No.	00
Marchio di omologazione Approval mark	IV  050131		

1. Trade name or mark of the equipment: RS
2. Type: RS-RM2511-EU CMS CLASS IV
3. Manufacturer's name and address: **Guangzhou Rongsheng Technology Co.,Ltd.**
4th Floor, G Building, Jiye Industrial Park, No. 270 Changjiang Road, Panyu District, Guangzhou City, Guangdong Province China 511447
4. If applicable, name and address of the manufacturer's representative: Not Applicable

5. Equipment submitted for approval on: 30.09.2022
6. Technical Service and, where applicable, test laboratory approved for purposes of approval or of verification of conformity: **AUTOMOTIVE TECHNICAL SERVICE S.r.l.**
Via Consiglio dei Sessanta, 99
47891 – DOGANA Repubblica di San Marino
7. Date of report issued by that service: 24.10.2022
8. Number of report issued by that service: ATS-SM-IR-46-04808
9. Vehicles for which the equipment is designed: M, N
10. Brief description
- 10.1. Identification of the device²: ~~Mirror~~, camera/monitor, ~~other device~~
- 10.2. Device for indirect vision of Classes²: I, II, III, IV, ~~V, VI, VII~~
- 10.3. Symbol $\frac{A}{2m}$ as defined in paragraph 6.3.1.1. of this Regulation²: Yes/No
11. Position of the Approval Mark: See Information Document No. RS-RM2511-EU CMS CLASS IV -00
12. Approval: **GRANTED**/~~REFUSED/EXTENDED/WITHDRAWN~~⁽²⁾
13. Reason(s) of extension of approval: Not Applicable
14. Place: DOGANA – Repubblica di San Marino
15. Date: 24.10.2022
16. Signature:



Ing. Marco CONTI
Direttore Generale
General Director

A list of documents contained in the approval file transmitted to the administrative service which has granted approval is annexed to this communication.

(2) Strike out which does not apply.

Allegato <i>Enclosure</i>				
Al certificato di omologazione ECE N. <i>To ECE approval certificate No.</i>		E57*46R05/00*0131*00		
Indice del fascicolo di omologazione <i>Index to the information package</i>				
Data <i>Date of issue</i>		24.10.2022	Data ultima modifica <i>Last amendment date</i>	--
1.	Clausole di garanzia e istruzioni sul diritto di presentare ricorso <i>Collateral clauses and instruction on right to appeal</i>			
2.	Rapporto(i) Finale di Ispezione N. <i>Inspection report(s) No.</i>	ATS-SM-IR-46-04808	Data <i>Date</i>	24.10.2022
3.	Scheda informativa N. <i>Information document No.</i>	RS-RM2511-EU CMS CLASS IV -00	Data <i>Date</i>	20.09.2022
			Data ultima modifica <i>Last amendment date</i>	--



Clausole di garanzia e istruzioni sul diritto di presentare ricorso

Clausole di garanzia

La produzione in serie deve essere esattamente conforme ai documenti di omologazione. Le variazioni di produzione in serie sono consentite solo con il consenso espresso del **Autorità per l'Omologazione**.

Le variazioni del nome della società, l'indirizzo e lo stabilimento di produzione, nonché una delle parti che hanno l'autorità alla consegna o eventuali rappresentanti nominati al momento del rilascio dell'omologazione, devono essere immediatamente comunicate al **Autorità per l'Omologazione**. La violazione di queste regole può portare al ritiro dell'omologazione ed inoltre può essere legalmente perseguita.

L'omologazione decade se viene restituita o ritirata o se il tipo omologato non è più conforme ai requisiti di legge. La revoca può essere fatta se non esistono più i requisiti richiesti per il rilascio e la continuazione dell'omologazione, se il titolare dell'omologazione viola gli obblighi dettati dall'omologazione, anche nel caso in cui gli obblighi derivino dalle condizioni assegnate all'interno dell'omologazione, o se è accertato che il tipo approvato non è conforme ai requisiti di sicurezza del traffico e di tutela dell'ambiente.

L'**Autorità per l'Omologazione** può verificare la corretta applicazione della delega conferita rilasciata nella presente omologazione, in qualsiasi momento. In particolare, questo include la verifica della produzione, che sia conforme, nonché le misure di controllo di conformità della produzione. Per questo, possono essere presi dei campioni dalla produzione. I dipendenti o rappresentanti dell'**Autorità per l'Omologazione** possono avere accesso senza ostacoli agli impianti di produzione e stoccaggio.

La delega conferita contenuta nella presente omologazione non è trasferibile. I diritti del marchio di terzi non sono interessati da questa omologazione.

Istruzione su diritto di ricorso

Questa omologazione è appellabile entro un mese dalla notifica. Il ricorso deve essere presentato per iscritto o come una domanda inviata all' **Autorità per l'Omologazione** - Via Consiglio dei Sessanta, 99 - 47891 Dogana - Repubblica di San Marino.

Collateral clauses and instruction on right to appeal

Collateral clauses

*The individual production of serial fabrication must be in exact accordance with the approval documents. Changes in the individual production are only allowed with express consent of the **Authority for Homologation**.*

*Changes in the name of the company, the address and the manufacturing plant as well as one of the parties given the authority to delivery or authorized representative named when the approval was granted is to be immediately disclosed to the **Authority for Homologation**. Breach of this regulation can lead to recall of the approval and moreover can be legally prosecuted.*

The approval expires if it is returned or withdrawn or if the type approved no longer complies with the legal requirements. The revocation can be made if the demanded requirements for issuance and the continuance of the approval no longer exist, if the holder of the approval violates the duties involved in the approval, also to the extent that they result from the assigned conditions to this approval, or if it is determined that the approved type does not comply with the requirements of traffic safety or environmental protection.

*The **Authority for Homologation** may check the proper exercise of the conferred authority taken from this approval at any time. In particular this means the compliant production as well as the measures for conformity of production. For this purpose samples can be taken or have taken. The employees or the representatives of the **Authority for Homologation** may get unhindered access to the production and storage facilities.*

The conferred authority contained with issuance of this approval is not transferable. Trade mark rights of third parties are not affected with this approval.

Instruction on right to appeal

*This approval can be appealed within one month after notification. The appeal is to be filed in writing or as a transcript at the **Authority for Homologation** - Via Consiglio dei Sessanta, 99 - 47891 Dogana - Repubblica di San Marino.*

Inspection Report No.: AT5-SM-IR-46-04808



Of: 24/10/2022

Type: RS-RM2511-EU CMS CLASS IV

Manufacturer: Guangzhou Rongsheng Technology Co.,Ltd.

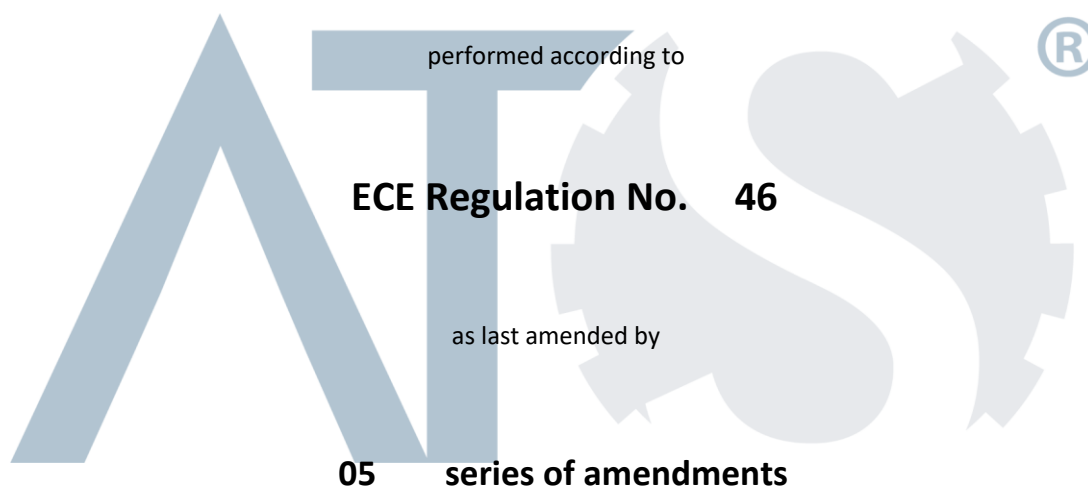
Inspection Report

No. AT5-SM-IR-46-04808

Rel. 00

Inspection concerning ~~vehicles~~ / components with regard to:

Uniform provisions concerning the approval of devices for indirect vision



of the Economic Commission for Europe

Approval status	
Number of approval	
ECE	E57*46R05/00*0131*00

Inspection Report No.: ATS-SM-IR-46-04808


Of: 24/10/2022



Type: RS-RM2511-EU CMS CLASS IV

Manufacturer: Guangzhou Rongsheng Technology Co.,Ltd.

0. General information

- 0.1. Make (trade name of manufacturer): RS
- 0.2. Type: RS-RM2511-EU CMS CLASS IV
- 0.2.1. Variants: RS-RM2511 CMS CLASS IV
- .3. Name and address of manufacturer: **Guangzhou Rongsheng Technology Co.,Ltd.**
4th Floor, G Building, Jiyi Industrial Park, No. 270 Changjiang Road, Panyu District, Guangzhou City, Guangdong Province China 511447
- 0.3.1 Name and address of manufacturer's authorized representative: N/A
- 0.3.2. Production plant(s) name and address(es): **Guangzhou Rongsheng Technology Co.,Ltd.**
4th Floor, G Building, Jiyi Industrial Park, No. 270 Changjiang Road, Panyu District, Guangzhou City, Guangdong Province China 511447
- 0.4. No. of the information document: RS-RM2511-EU CMS CLASS IV -00 Date: 20/09/2022
- 0.5. Identification of the device: ~~mirror~~, camera/monitor, ~~other device~~
- 0.6. Class(es) of Device for indirect vision: I, II, III, IV, V, VI, VII
- 0.7. Symbol  as defined in paragraph 6.3.1.1. of this Regulation: N/A
- 0.8. Position of the approval mark: See information document
- 0.9. Vehicle category: M, N

Inspection Report No.: ATS-SM-IR-46-04808



Of: 24/10/2022

Type: RS-RM2511-EU CMS CLASS IV

Manufacturer: Guangzhou Rongsheng Technology Co.,Ltd.

1. Tested vehicle(s) / object(s)

- 1.1. Description: Electronic rearview mirror
- 1.1.1. Vehicle/object: ~~Vehicle~~ / Object
- 1.1.2. Tested object(s): ~~Class I, Class II, Class III, Class IV, Class V, Class VI, Class VII~~
- 1.1.2.1 Control System: Electric Control
- 1.1.3. Variant/version: RS-RM2511 CMS CLASS IV
- 1.1.4. Vehicle identification number: N/A
- 1.1.5. Test performed by laboratory: GUANGZHOU SHUNTAI QUALITY TECHNICAL SERVICE CO., LTD.
- 1.1.5.1. Equipment for measuring and testing:
 - Imaging photometer
 - Illumination photometer
 - Luminance meter
 - Electronic focusing lens
 - CMS test system

1.2 General Requirements

1.2.1 The mirror is adjustable: Applicable / Not Applicable

1.2.1.1 The edge of the reflecting surface shall be enclosed in a protective housing (holder, etc.) which, on its perimeter, shall have a value 'c' greater than or equal to 2,5 mm at all points and in all directions. If the reflecting surface projects beyond the protective housing, the radius of curvature 'c' on the edge of the projecting part shall be not less than 2,5 mm and the reflecting surface shall return into the protective housing under a force of 50 N applied to the point of greatest projection, relative to the protective housing, in a horizontal direction, approximately parallel to the longitudinal median plane of the vehicle. Applicable / Not Applicable

1.2.1.2 When the mirror is mounted on a plane surface, all parts, irrespective of the adjustment position of the device, including those parts remaining attached to the support after the test provided for in paragraph 6.1.3.2 below, which are in potential, static contact with a sphere 100 mm in diameter in the case of an exterior mirror, shall have a radius of curvature 'c' of not less than 2,5 mm. Applicable / Not Applicable

1.2.2 The requirements in paragraphs above shall not apply to parts of the external surface which protrude less than 5 mm, but the outward facing angles of such parts shall be blunted, save where such parts protrude less than 1.5 mm. For determining the dimension of the projection, the following method shall apply:

1.2.2.1 The dimension of the projection of a component which is mounted on a convex surface may be determined either directly or by reference to a drawing of an appropriate section of this component in its installed condition. Applicable / Not Applicable

1.2.2.2 If the dimension of the projection of a component which is mounted on a surface other than convex cannot be determined by simple measurement, it shall be determined by the maximum variation of the distance of the center of a 100 mm diameter sphere from the nominal line of the panel when the sphere is moved over and is in constant contact with that component. Applicable / Not Applicable



1.2.3. Edges of fixing holes or recesses of which the diameter or longest diagonal is less than 12 mm are exempt from the radius requirements of paragraph 6.1.1.3. of Regulation ECE R46 above provided that they are blunted. Applicable / Not Applicable

1.2.4. The device for the attachment of mirrors to the vehicle shall be so designed that a cylinder with a 70 mm radius (50 mm in the case of an L-category vehicle), having as its axis the axis, or one of the axes, of pivot or rotation which ensures deflection of the mirror in the direction of impact concerned, passes through at least part of the surface to which the device is attached. Applicable / Not Applicable

1.2.5. The contours of the reflecting surface shall be of simple geometric form and its dimensions such that the mirror provides the field of vision specified in paragraph 15.2.4.6 of Regulation ECE R46. Applicable / Not Applicable

1.2.6. Reflecting surface and coefficients of reflection requirements are in according to point 6.1.2.2 of Regulation ECE R46. Applicable / Not Applicable

1.2.6.b The reflecting surface shall retain the characteristics of reflection in spite of prolonged exposure to adverse weather conditions in normal use. Applicable / Not Applicable

1.2.6.1 'r' expressed in mm is calculated from the formula: Applicable / Not Applicable
Sample 1: r=--
Sample 2: r=--

$$r = \frac{rp1 + rp2 + rp3}{3}$$

Where:
rp1 = the radius of curvature at the first measuring point,
rp2 = the radius of curvature at the second measuring point,
rp3 = the radius of curvature at the third measuring point.

1.2.6.2 Verification regarding the differences between the radii of curvature of mirrors according 6.1.2.2.2. Applicable / Not Applicable

1.2.7. The test provided for in paragraph 6.1.3.2 below shall not be required in the case of any exterior mirror of which no part is less than 2 m from the ground, regardless of the adjustment position, when the vehicle is under a load corresponding to its maximum technically permissible mass. Applicable / Not Applicable

1.2.8 If applicable, a description specifying that the mirror shall be mounted so as to conform to the above-mentioned conditions for the positioning of its attachments on the vehicle shall be provided. Applicable / Not Applicable


1.2.8.1 If applicable, the arm shall be indelibly marked with the symbol $\frac{\Delta}{2m}$ ~~Applicable~~ / Not Applicable

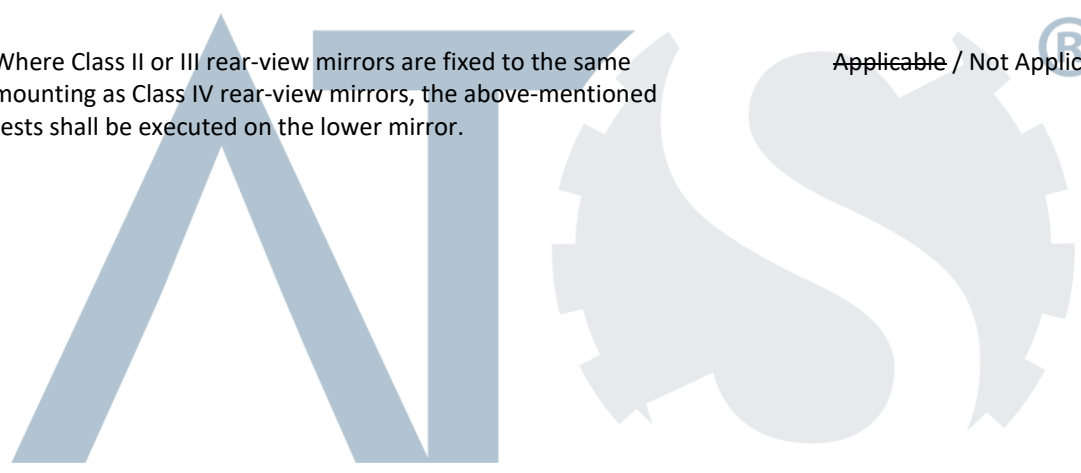
1.3 Impact test ~~Applicable~~ / Not Applicable

1.3.1. The device and the test conditions are in according to paragraph 6.3.2.2 of Regulation ECE R46. ~~Applicable~~ / Not Applicable

1.3.1.1 Test 1: The point of impact shall be as defined in paragraph 6.3.2.2.3 or 6.3.2.2.5 above. The impact shall be such that the hammer strikes the mirror on the reflecting surface side. ~~Applicable~~ / Not Applicable

1.3.1.2 Test 2: The point of impact shall be as defined in paragraph 6.3.2.2.3 or 6.3.2.2.5 above. The impact shall be such that the hammer strikes the mirror on the side opposite to the reflecting surface. ~~Applicable~~ / Not Applicable

1.3.1.3 Where Class II or III rear-view mirrors are fixed to the same mounting as Class IV rear-view mirrors, the above-mentioned tests shall be executed on the lower mirror. ~~Applicable~~ / Not Applicable 



1.4. Devices for indirect vision other than mirrors – camera monitoring systems (CMS) - prescriptions according to ECE R46 par. 6.2.

Applicable / ~~Not Applicable~~

Below items are taken from ECE Regulation No. 46

6.2.1. General requirements

6.2.1.1. If adjustment by the user is needed, the device for indirect vision shall be adjustable without the use of tools.

Conform / ~~Not Conform~~

6.2.1.2. If a device for indirect vision can only render the total prescribed field of vision by scanning the field of vision, the total process of scanning, rendering and reset to its initial position together shall not take more than 200 milliseconds at room temperature of 22 °C ± 5 °C.

Conform / ~~Not Conform~~

6.2.1.3. The effectiveness of the CMS of Classes I to VI shall not be adversely affected by magnetic or electrical fields. This shall be demonstrated by compliance with the technical requirements and transitional provisions of Regulation No. 10, 04 series of amendments or any later series of amendments.

Conform / ~~Not Conform~~

6.2.2. Camera monitoring systems

Applicable / ~~Not Applicable~~

The requirements of paragraph 6.2.2.1. shall be considered to be satisfied in the case of monitors of a vehicle that fulfills the provisions of Regulation No. 21.

Conform / ~~Not Conform~~

6.2.2.1. General requirements

6.2.2.1.1. When the devices of the camera-monitor system are mounted in the position recommended by the manufacturer for normal driving, all parts, irrespective of the adjustment position of the device, including those parts remaining attached to the support after the test provided for the paragraph 6.3.2. below which are in potential, static contact with a sphere either 165 mm in diameter in the case of a CMS or parts of CMS installed inside the vehicle or 100 mm in diameter in the case of a CMS or parts of CMS installed outside the vehicle, shall have a radius of curvature "c" of not less than 2.5 mm.

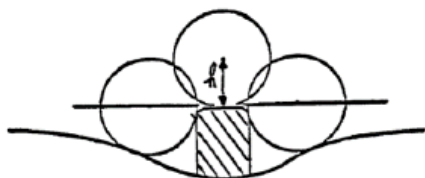
Conform / ~~Not Conform~~

6.2.2.1.2. The requirements in paragraph 6.2.2.1.1. above shall not apply to parts of the external surface which protrude less than 5 mm, but the outward facing angles of such parts shall be blunted, and are considered save where such parts protrude less than 1.5 mm. For determining the dimension of the projection, the following method shall apply:

Conform / ~~Not Conform~~

6.2.2.1.2.1. The dimension of the projection of a component which is mounted on a convex surface may be determined either directly or by reference to a drawing of an appropriate section of this component in its installed condition. Applicable / ~~Not Applicable~~

6.2.2.1.2.2. If the dimension of the projection of a component which is mounted on a surface other than convex cannot be determined by simple measurement, it shall be determined by the maximum variation of the distance of the centre of a 100mm diameter sphere from the nominal line of the panel when the sphere is moved over and is in constant contact with that component. Figure 1 shows an example of the use of this procedure. Conform / ~~Not Conform~~



6.2.2.1.3. Edges of fixing holes or recesses of which the diameter or longest diagonal is less than 12 mm are exempt from the radius requirements of paragraph 6.2.2.1.1. above provided that they are blunted. Conform / ~~Not Conform~~

6.2.2.1.4. For parts of the camera and the monitor which are made of a material with a Shore A hardness of less than 60 and which are mounted on a rigid support, the requirements of paragraph 6.2.2.1.1. above shall only apply to the support. Conform / ~~Not Conform~~

6.2.2.1.5. The requirements of paragraph 6.2.2.1.1. do not apply to CMS if their lower edge is mounted not less than 2m above the ground when the vehicle is under a load corresponding to its maximum technical permissible mass. Conform / ~~Not Conform~~

6.2.2.2. Functional requirements for camera-monitor devices of Classes V and VI Applicable / Not Applicable

6.2.2.2.1. The camera shall function well in conditions in which sunlight falls on the camera. The saturated area, defined as the area in which the luminance contrast ratio ($C=L_w/L_b$) of a high contrast pattern falls below 2.0, shall not cover more than 15 per cent of the displayed image under the conditions of paragraphs 6.2.2.2.1.1. to 6.2.2.2.1.4. below. Applicable / Not Applicable

In the case the camera system shows dynamical changes in the blooming area during the test the maximum blooming area shall fulfill the requirements. Applicable / Not Applicable

6.2.2.2.1.1. A black and white test pattern, having a minimum contrast ratio of 20 shall be positioned in front of the camera. Applicable / Not Applicable

The test pattern shall be evenly illuminated at an illumination of 3,000 ± 300 lx.

Applicable / Not Applicable

The test pattern shall be medium gray on average and cover the complete area viewed by the camera; the camera shall view no other objects than the test pattern.

Applicable / Not Applicable

6.2.2.2.1.2. The camera shall be hit by a (simulated sun) light of 40 klx, spanning an angle between 0.6 and 0.9° with an elevation angle of 10° (directly or indirectly via a mirror) removed from the optical axis of the sensor.

Applicable / Not Applicable

The light source shall:

Applicable / Not Applicable

- (a) Have a spectrum D65 with a tolerance of ±1,500 K;
- (b) Be homogeneous in space and time within a tolerance of 2 klx.

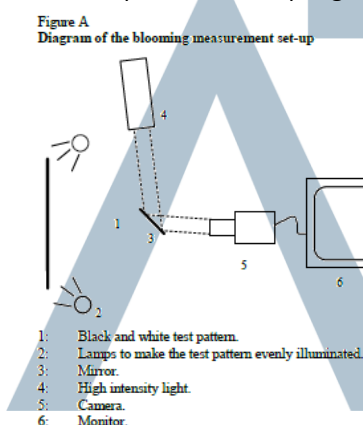
The emission of the light source in infrared shall be negligible.

Applicable / Not Applicable

6.2.2.2.1.3. There shall be no ambient illumination of the monitor during the test.

Applicable / Not Applicable

6.2.2.2.1.4. An example of the set-up is given in the Figure A below.



6.2.2.2.2. The monitor shall render a minimum contrast under various light conditions as specified by ISO 15008:2003.

Applicable / Not Applicable

6.2.2.2.3. It shall be possible to adjust the average luminance of the monitor either manually or automatically to the ambient conditions.

Applicable / Not Applicable

6.2.2.2.4. The measurements for the luminance contrast of the monitor shall be carried out according to ISO 15008:2009.

Applicable / Not Applicable

6.2.2.3. **Functional requirements for camera-monitor devices of Classes I to IV (see Annex 12).**

Applicable / ~~Not Applicable~~

Unless otherwise specified in this Regulation, the definitions and symbols used in paragraph 6.2.2.3. are in accordance with ISO

Conform / ~~Not Conform~~

16505:2015, Chapters 3 and 4.

Unless otherwise specified in this Regulation, the requirements given in paragraph 6.2.2.3. shall be verified according to the test procedures given in ISO 16505:2015, Chapter 7, where available.

Conform / ~~Not Conform~~

6.2.2.3.1. Luminance adjustment

It shall be possible to adjust the average luminance of the monitor either manually or automatically to the ambient conditions.

Conform / ~~Not Conform~~

6.2.2.3.2. Operating readiness (System availability)

If the system is not operational (e.g. CMS failure), it shall be indicated to the driver by i.e. warning indication, display information, absence of status indicator. The operator's manual shall explain the information indicated.

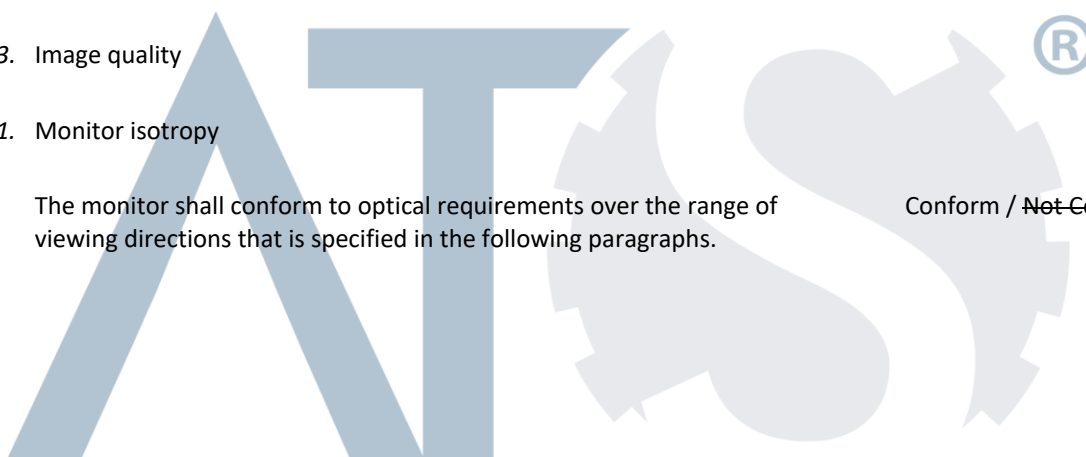
Conform / ~~Not Conform~~

6.2.2.3.3. Image quality

6.2.2.3.3.1. Monitor isotropy

The monitor shall conform to optical requirements over the range of viewing directions that is specified in the following paragraphs.

Conform / ~~Not Conform~~



6.2.2.3.3.1.1. Directional uniformity

When driven by an artificial 70 per cent grey-scale image, the deviation of the monitor luminance from the luminance white level with specific viewing direction $(\Theta, \varphi) = (\Theta_{\text{monitor}/D}, \varphi_{\text{monitor}/D})$ shall be such that the ratio relative to the luminance white level for the same specific viewing direction $L(\Theta_{\text{monitor}/D}, \varphi_{\text{monitor}/D})$ does not exceed 35 per cent of the luminance white level for the monitor standard isotropy range and shall not exceed 50 per cent of the luminance white level for the monitor extended isotropy range.

Conform / ~~Not Conform~~

For the standard isotropy range:

Conform / ~~Not Conform~~

$$\frac{\max \{L_i - L(\Theta_{\text{monitor}/D}, \Phi_{\text{monitor}/D})\}}{L(\Theta_{\text{monitor}/D}, \Phi_{\text{monitor}/D})} < 35\%$$

for points $i = 1, 2, 3, 4, 5, 6, 7, 8, 9$ as defined in Table below.

Direction i	horizontal/ degree	vertical/ degree
1	-7	+6
2	0	+6
3	+7	+6
4	-7	0
5	N/A	N/A
6	+7	0
7	-7	-6
8	0	-6
9	+7	-6

For the extended isotropy range:

Conform / ~~Not Conform~~

$$\frac{\max \{L_i - L(\Theta_{\text{monitor}/D}, \Phi_{\text{monitor}/D})\}}{L(\Theta_{\text{monitor}/D}, \Phi_{\text{monitor}/D})} < 50\%$$

for points $i' = 1, 2, 3, 4, 5, 6, 7, 8, 9$ as defined in Table below



<i>Direction i'</i>	<i>horizontal/ degree</i>	<i>vertical/ degree</i>
1	-12	+11
2	0	+11
3	+12	+11
4	-12	0
5	N/A	N/A
6	+12	0
7	-12	-11
8	0	-11
9	+12	-11

6.2.2.3.3.1.2. Lateral uniformity

The luminance white lateral dependency shall satisfy:

Conform / ~~Not Conform~~

$$\frac{\max \{L_{j/white}(\Theta, \Phi)\} - \min \{L_{j/white}(\Theta, \Phi)\}}{\max \{L_{j/white}(\Theta, \Phi)\}} < 35\%$$

for points j = 1, 2, 3, 4, 5, 6, 7, 8, 9 as defined in Table below, where (Θ, φ) = (0, 0).

<i>Point j</i>	<i>Percentage of Wmonitor/horizontal from top left corner</i>	<i>Percentage of Hmonitor/horizontal from top left corner</i>
1	20	20
2	50	20
3	80	20
4	20	50
5	50	50
6	80	50
7	20	80
8	50	80
9	80	80

6.2.2.3.3.2. Luminance and contrast rendering

For luminance and contrast rendering the following requirements shall apply:

Conform / ~~Not Conform~~

(a) The minimum luminance contrast at the monitor (including any screen protector) reproducing a high contrast pattern shall be:

- (i) For direct sunlight condition: 2:1;
- (ii) For day condition with diffuse ambient light: 3:1;
- (iii) For sunset condition: 2:1;
- (iv) For night condition: 10:1 except in the case of Mirror and CMS dual function system of class I: 5:1.

Conform / ~~Not Conform~~

(b) The night condition for the camera's field of view is replicated in a dark environment such that the maximum illuminance on the objects to be measured shall not exceed 2.0 lx;

Conform / ~~Not Conform~~

(c) The background luminance of the monitor shall be limited under the night condition. The maximum background luminance under the night condition shall be less than 2.0 cd/m²;

Conform / ~~Not Conform~~

(d) The instructions for use shall contain a note that sunlight or light from other intense light source upon the monitor reduces the luminance contrast which may require the driver to be particularly alert and attentive.

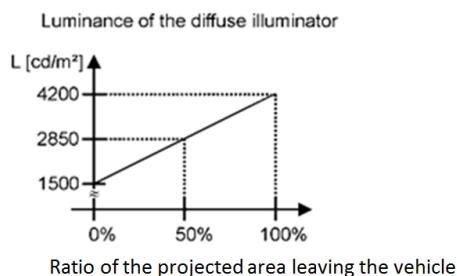
6.2.2.3.3.2.1. Day condition with diffuse sky-light exposure test

For the day condition with diffuse sky-light exposure, the test method given in ISO 16505:2015, subclause 7.8.2., Test 2 shall be applied, but a value of 4,000 to 4,200 cd/m² for luminance diffuse illuminator shall be used.

Conform / ~~Not Conform~~

At the request of the manufacturer, the value for luminance diffuse illuminator may be determined by using the diagram of figure below.

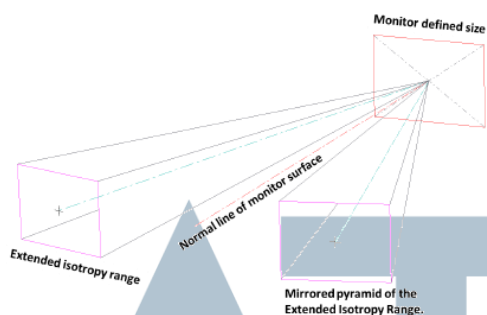
Conform / ~~Not Conform~~



Ratio of projected area vs. luminance of the diffuse illuminator

Procedure for determining the ration of the projected area leaving the vehicle:

- (a) Determine the projected area in the vehicle that represents the mirror reflected direction from the monitor extended isotropy range.
- (b) Evaluation shall be made in the centre of the monitor defined size, under consideration of the monitor design viewing direction (see figure below).



This projected area represents the 100 per cent of the surface to be considered.

Based on virtual testing, evaluate the ratio of the projected area that leaves the vehicle openings (e.g. through a side door window, rear window or sunroof; however, for example a sunroof having an opaque shutter shall not be considered an opening).

Conform / ~~Not Conform~~

Case when the orientation of the mirror and CMS dual function system of Class I is adjustable:

~~Applicable~~ / Not Applicable

Based on virtual testing, if the applicant demonstrates that the Mirror and CMS dual function system of Class I adjustment range permits a driver to avoid any incident specular light from the vehicle opening while a driver's eye is within any fixed position of the standard isotropy range, then the value for luminance diffuse illuminator shall be the one of ISO 16505:2015 subclause 7.8.2., Test 2: 1,300 to 1,500 cd/m².

6.2.2.3.3.3. Grey scale rendering

A CMS shall have a sufficient grey scale rendering. CMS shall display a tonal range of at least eight distinguishable different grey tonal steps on the monitor.

Conform / ~~Not Conform~~

For the grey scale rendering, the test method of paragraph 1.4. of Annex 12 shall be applied.

Conform / ~~Not Conform~~

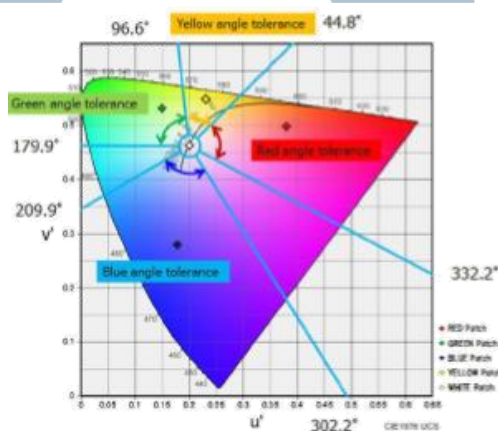
6.2.2.3.3.4. Colour rendering

For colour rendering, the hue angle of reproduced colour of the chart patches on the monitor shall satisfy the following requirements. The colour coordinates are described based in the CIE 1976 uniform colour space:

Conform / ~~Not Conform~~

- (a) Red colour coordinates shall not exceed the range of (0°, 44.8°) or (332.2°, 360°);
- (b) Green colour coordinates shall not exceed the range of (96.6°, 179.9°);
- (c) Blue colour coordinates shall not exceed the range of (209.9°, 302.2°);
- (d) Yellow colour coordinates shall not exceed the range of (44.8°, 96.6°);
- (e) To distinguish from the white colour, define distance from white as $R_i \geq 0.02$, where R_i is the chromatic distance of each colour patch (i = Red, Green, Blue, Yellow), relative to white (i = White).

Figure below shows an illustrative tolerance range described on CIE 1976 uniform colour space.



Amber, blue and red light signals shall be distinguishable from each other.

Conform / ~~Not Conform~~

6.2.2.3.3.5. Artefacts

The operator's manual shall refer to possible artefacts and their impact on the partial occlusion of the field of view and of the objects which may require the driver to be particularly alert and attentive.

Conform / ~~Not Conform~~

6.2.2.3.3.5.1. Smear

Smear shall be transparent and not be more than 10 per cent of the maximum luminance value of the displayed glare source luminance level, which causes smear effect.

Conform / ~~Not Conform~~

6.2.2.3.3.5.2. Blooming and lens flare

The total area of disturbing blooming and lens flare areas shall not cover more than 25 per cent of the displayed camera image.

Conform / ~~Not Conform~~

6.2.2.3.3.5.3. Point light sources

The CMS shall have an operation mode in which the driver of the vehicle equipped with CMS can recognize two point light sources (e.g. passing beam headlights) rendered as two distinguishable separate point light sources.

Conform / ~~Not Conform~~

In this operation mode, a set of two point light sources corresponding to a vehicle passing beam headlamp each having a reference luminous intensity 1,750 cd and being separated each other laterally by 1.3 m and located at a distance of 250 m away from the CMS shall be distinguishable as two point light source. This requirement is applicable to Class I, Class II and Class III devices for indirect vision.

Conform / ~~Not Conform~~

The point light source detection factor (PLSDF) shall be at least 2.7 or the point light source contrast factor (PLSCF) shall be at least 0.12, whichever is satisfied by the CMS test under the conditions and the test procedure described in Annex 12, paragraph 1.3.

Conform / ~~Not Conform~~

If the system is in a mode where point light sources are not rendered as described above, this shall be indicated to the driver. The information indicated shall be explained in the operator's manual.

Conform / ~~Not Conform~~

6.2.2.3.3.6. Sharpness and depth of field

Sharpness

The sharpness is represented by the MTF50(1:1) and it shall satisfy:

(a) Horizontal and vertical MTF50(1:1) at center Conform / ~~Not Conform~~

$$MTF50_{(H)} \geq \frac{1}{2} MTF10_{MIN(H)} \langle LW / PH \rangle$$

(b) Horizontal and vertical MTF50(1:1) at corners (70 per cent of image height) Conform / ~~Not Conform~~

$$MTF50_{(H)} \geq \frac{1}{2} \cdot \frac{1}{2} (MTF10_{MIN(H)}) \langle LW / PH \rangle$$

6.2.2.3.3.6.2. Depth of field

The CMS shall enable the driver to observe the occupied space by the object and perceive the content shown within the range of interest with detailed resolution. The MTF10(1:1), when measured at different distances to the object, shall satisfy at least the minimum resolution for the following points: Conform / ~~Not Conform~~

(a) Resolution at point 1 (10 m as representative point for infinity) and point 2 (middle distance at 6 m) Conform / ~~Not Conform~~

$$MTF10_{(H)} \geq 0,9 \cdot MTF10_{MIN(H)} \langle LW / PH \rangle$$

(b) Resolution at point 3 (Close distance at 4 meters) Conform / ~~Not Conform~~

$$MTF10_{(H)} \geq \frac{1}{2} MTF10_{MIN(H)} \langle LW / PH \rangle$$

6.2.2.3.3.7. Geometric distortion

For CMS of Classes I, II and III the maximum distortion within the minimum required field of view shall not exceed 20 per cent relative to recto-linear or pinhole projection. Conform / ~~Not Conform~~

This performance shall be tested according to the method given in ISO 16505:2015, Annex G.3. Conform / ~~Not Conform~~

6.2.2.3.3.8. Further image quality requirements

6.2.2.3.3.8.1. Flicker

The entire image area of the monitor shall be free of flicker according to the test method of Annex 12, paragraph 1.2.

Conform / ~~Not Conform~~

6.2.2.3.4. Time behaviour

6.2.2.3.4.1. Frame rate

Movements of objects in front of the camera shall be rendered smooth and fluid. The minimum frame rate of the system (update rate of the image information) shall be at least 30 Hz. At low light conditions or while maneuvering at low speed, the minimum frame rate of the system (i.e. update rate of the image information) shall be at least 15 Hz.

Conform / ~~Not Conform~~

6.2.2.3.4.2. Image formation time

The image formation time of the monitor shall be less than 55 ms at a temperature of 22 °C ± 5 °C.

Conform / ~~Not Conform~~

This performance shall be tested according to the method given in ISO 9241-305:2008.

Conform / ~~Not Conform~~

6.2.2.3.4.3. System latency

A CMS shall have a sufficient short latency to render the scenery nearly at the same time. The latency shall be lower than 200 ms at room temperature 22 °C ± 5 °C.

Conform / ~~Not Conform~~

6.2.2.3.5. Quality and further ergonomic requirements

6.2.2.3.5.1. Glare due to high luminance of the monitor

In order to avoid glare from a high luminance of the monitor, the luminance shall be dimmable in the night condition either manually or automatically.

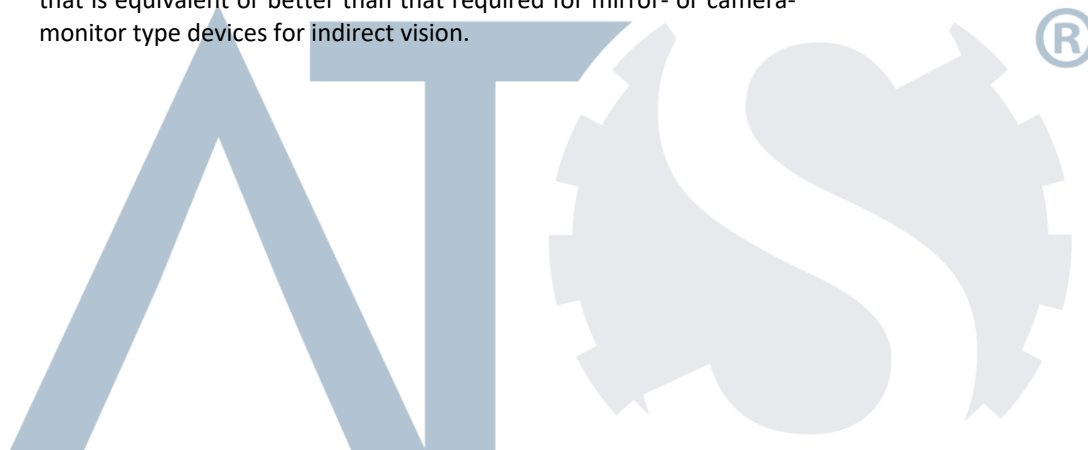
Conform / ~~Not Conform~~

6.2.3. Other devices for indirect vision

~~Applicable~~ / Not Applicable

It has to be proved that the device meets the following requirements:

- 6.2.3.1. The device shall perceive the visual spectrum and shall always render this image without the need for interpretation into the visual spectrum.
- 6.2.3.2. The functionality shall be guaranteed under the circumstances of use in which the system shall be put into service. Depending on the technology used in obtaining images and presenting them paragraph 6.2.2.2. above shall be entirely or partly applicable. In other cases this can be achieved by establishing and demonstrating by means of system sensitivity analogous to paragraph 6.2.2.2. above that a function is ensured that is comparable to or better than what is required for and by demonstrating that a functionality is guaranteed that is equivalent or better than that required for mirror- or camera-monitor type devices for indirect vision.



2. Other information

Place of inspection: Guangzhou Shuntai Quality Technical Service Co, Ltd.

Date of inspection: 21/10/2022

Technical service representative:	Senior Inspector	Junior Inspector (if applicable)
	Cheryl Deng	N/A

Manufacturer’s representative: None

Remarks:

2.1. Appendix

- | | |
|---|------------|
| 1. List of modifications | Appendix 1 |
| 2. Test results according to ECE R 46 par. 6.2. | Appendix 2 |
| 3. Test Photo (s) | Appendix 3 |

2.2. Enclosures

Information Folder

RS-RM2511-EU CMS CLASS IV-00

3. Statement of conformity

The information document as given in paragraph 0.4 and the type described there are in compliance with the test specification mentioned above.






With regard to the required level of performance to be achieved, the tested items were representative for the type to be approved (see paragraph 1).

The tests were carried out in accordance with the relevant requirements of EN ISO/IEC 17025 and EN ISO/IEC 17020 / ECE/UN R46-05.

The inspection report comprises pages 1 to 48.

It shall not be reproduced except in full, without written approval of the laboratory.

Dogana, Repubblica di San Marino, 24/10/2022

Number of project and protocol	Originality Check (*)	Automotive Technical Service S.r.l. Inspector	 
	 AT5-SM-PR-04808	 (Cheryl Deng)	
		Automotive Technical Service S.r.l. Deputy Technical Director	
		 (Eng. Bogdan Nicolae Domnescu)	

(*) To check the originality of documents, scan the QR Code or connect to the site <https://www.ats.sm/originality-control-atp-adr-tyapp/> and follow the instruction in it.

Inspection Report No.: ATS-SM-IR-46-04808



Of: 24/10/2022

Type: RS-RM2511-EU CMS CLASS IV

Manufacturer: Guangzhou Rongsheng Technology Co.,Ltd.

Appendix 1

List of modifications

Applicable / Not Applicable

Appendix 1

More details for application of

Date :

Correction of : -

Modification of : -

Addition of : -

Deletion of : -



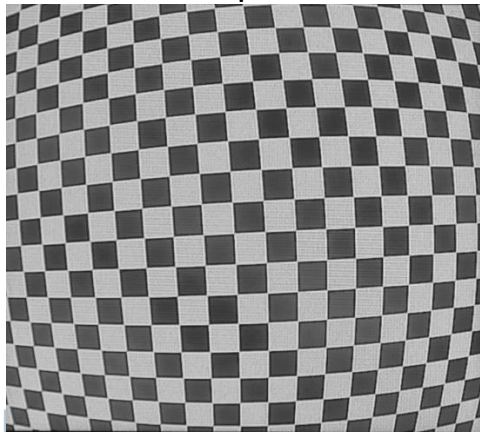
Appendix 2

Test results according to ECE R46
par. 6.2.

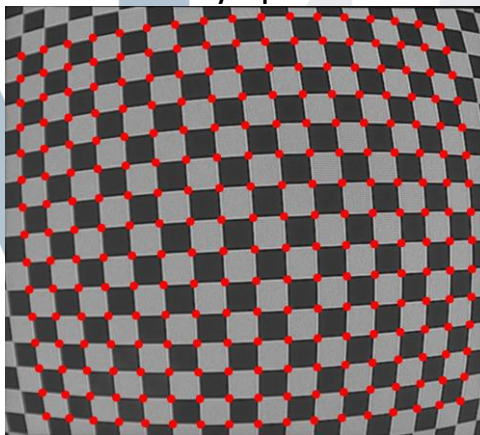
Appendix 2

Minimum magnification factor

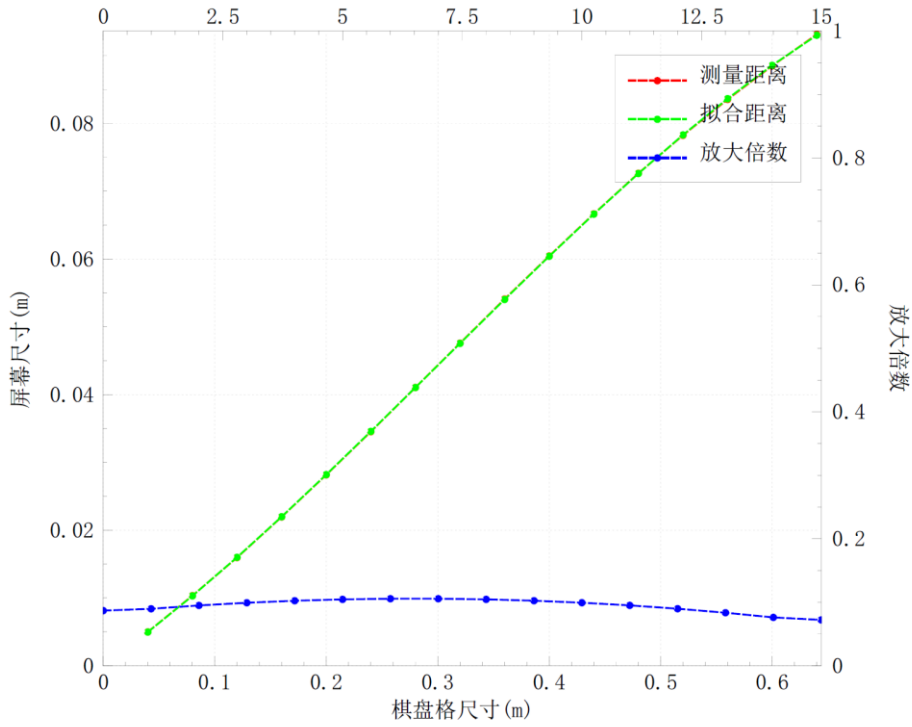
Take picture



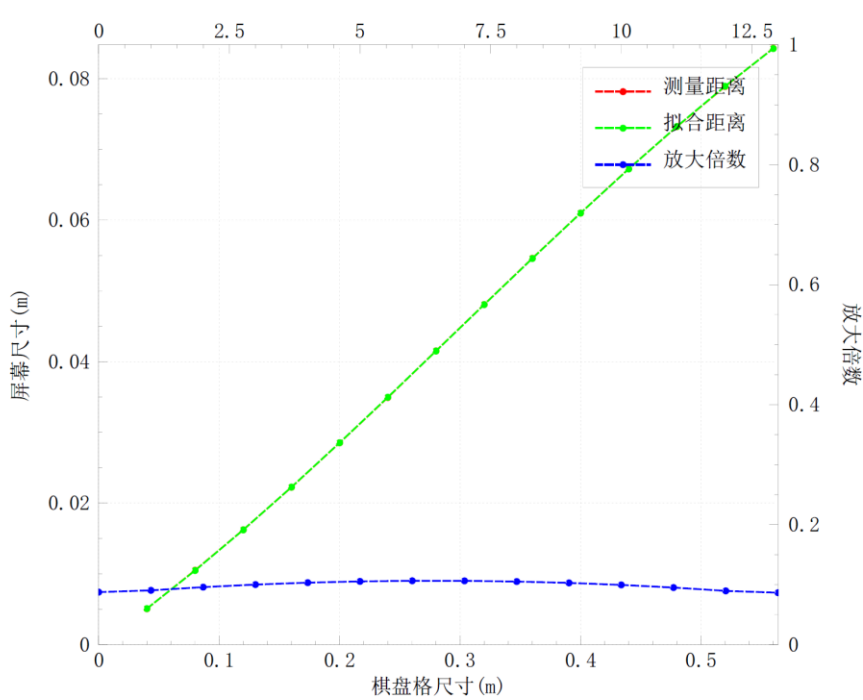
Analysis points



Curve of horizontal magnification factor



Curve of vertical magnification factor




Test result

Item	Standard request	Test data	Test result
Horizontal minimum magnification factor	IV for driver's side >0.054	0.0688997	PASS
	IV for passenger's side >0.016	0.0451801	PASS
Vertical minimum magnification factor	IV for driver's side >0.054	0.0773271	PASS
	IV for passenger's side >0.016	0.0507063	PASS

Average magnification factor

Test result

Item	Standard request	Test data	Test result
Horizontal minimum magnification factor	IV for driver's side >0.091	0.110111	PASS 
	IV for passenger's side >0.046	0.072268	PASS
Vertical minimum magnification factor	IV for driver's side >0.091	0.109245	PASS
	IV for passenger's side >0.046	0.072617	PASS

Inspection Report No.: ATS-SM-IR-46-04808



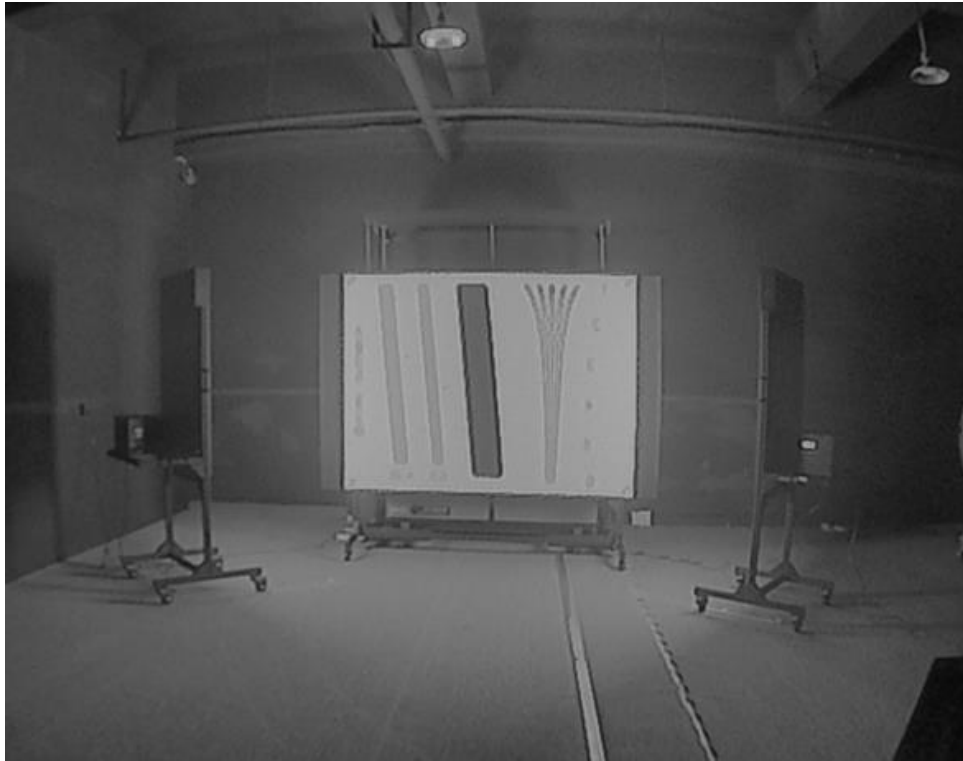
Of: 24/10/2022

Type: RS-RM2511-EU CMS CLASS IV

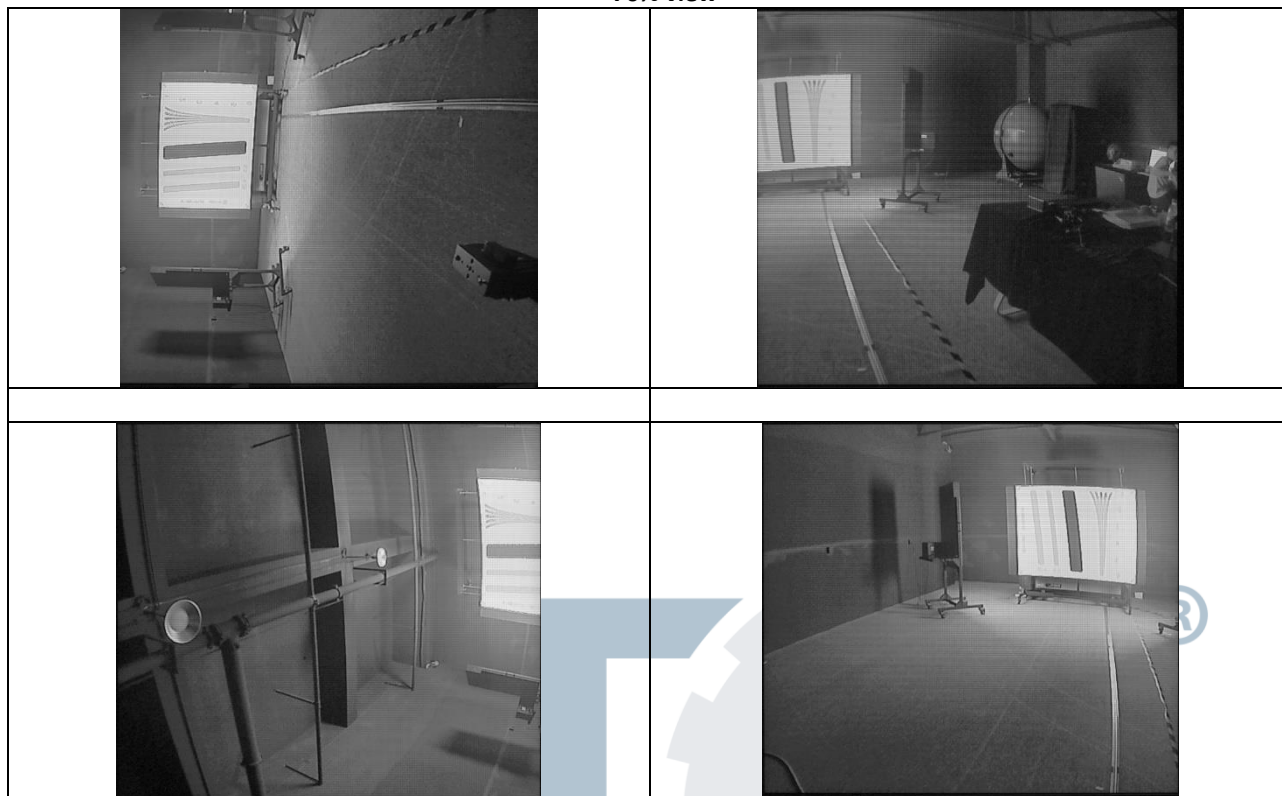
Manufacturer: Guangzhou Rongsheng Technology Co.,Ltd.

Resolution

Taking Pictures- The center view



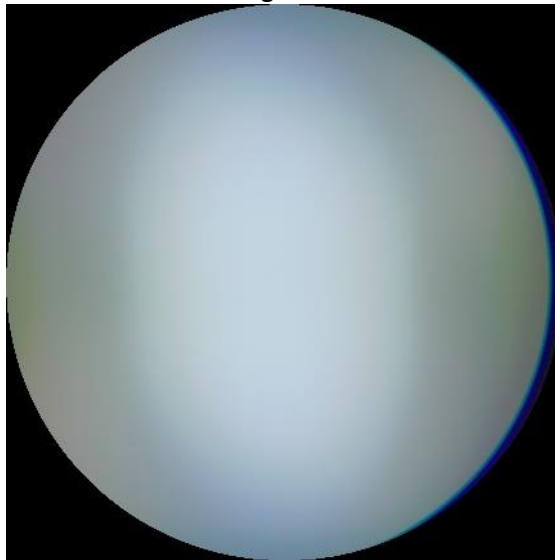
70% view



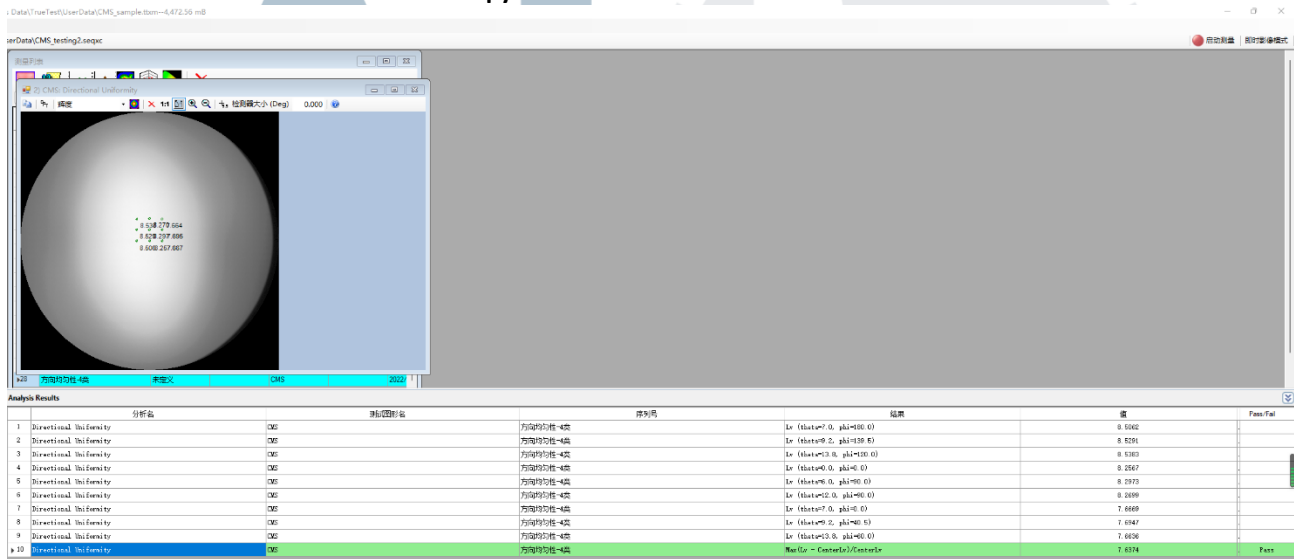
Item	Test data	Test result
MTF10MIN(1:1)/hor	223.08	PASS
MTF10MIN(1:1)/ver	196.56	PASS
Left bottom P value in horizontal direction of 70% FOV	0.735585	PASS
Left bottom P value in vertical direction of 70% FOV	0.687988	PASS
Left top P value in horizontal direction of 70% FOV	0.380873	PASS
Left top P value in vertical direction of 70% FOV	0.758294	PASS
Right bottom P value in horizontal direction of 70% FOV	0.364659	PASS
Right bottom P value in vertical direction of 70% FOV	0.708075	PASS
Right top P value in horizontal direction of 70% FOV	0.397257	PASS
Right top P value in vertical direction of 70% FOV	0.712288	PASS

Directional uniformity

Taking Pictures



Luminance of directions for standard isotropy



Inspection Report No.: ATS-SM-IR-46-04808

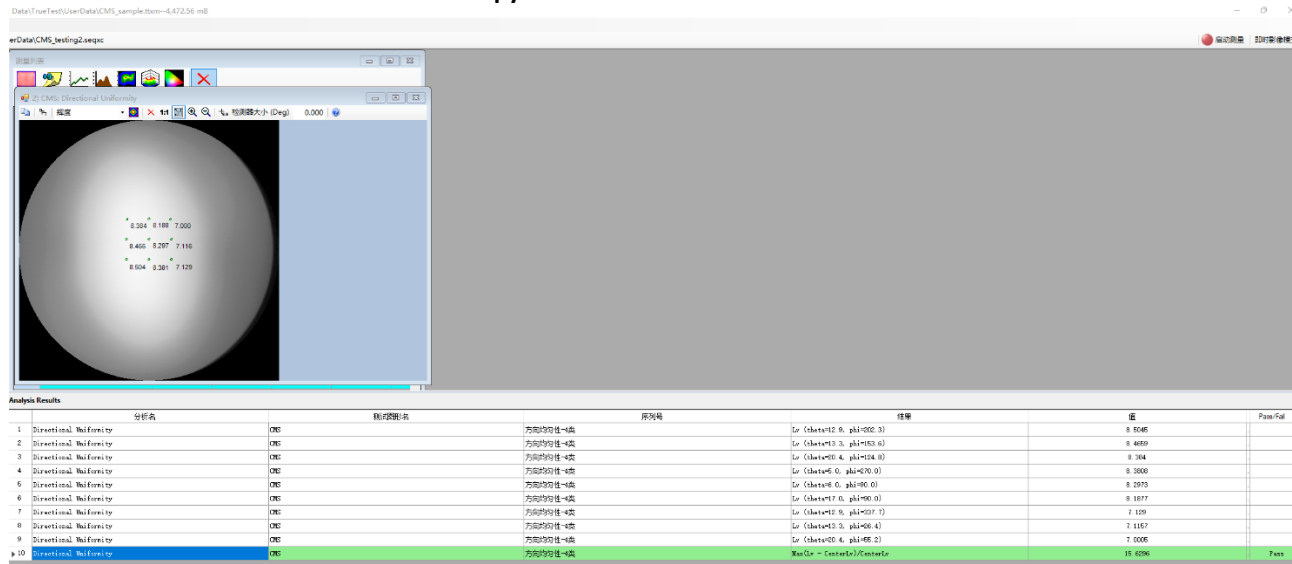


Of: 24/10/2022

Type: RS-RM2511-EU CMS CLASS IV

Manufacturer: Guangzhou Rongsheng Technology Co.,Ltd.

Luminance of directions for extended isotropy

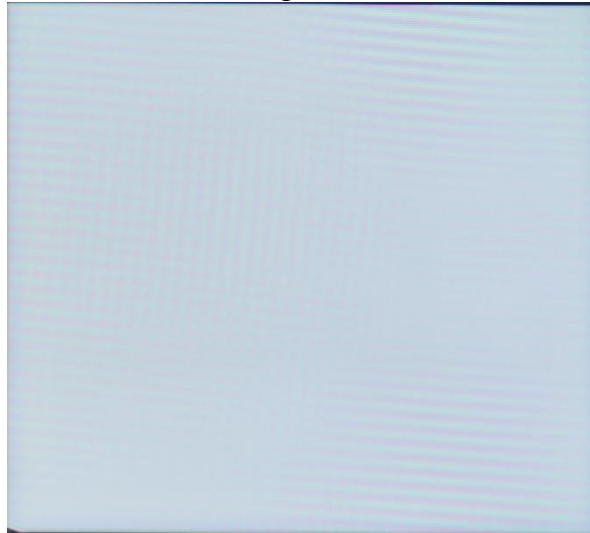


Test result

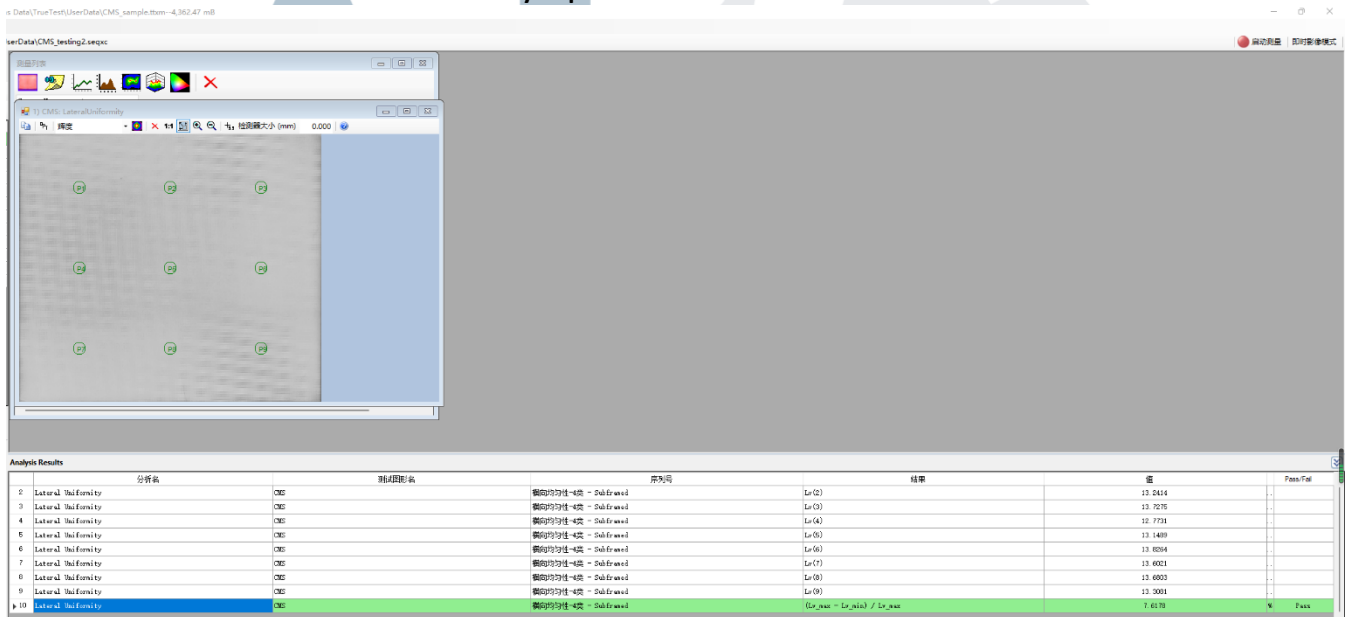
Item	Standard request	Test data	Test result
Directions for standard isotropy	<35%	7.635%	PASS
Directions for extended isotropy	<50%	15.629%	PASS

Lateral Uniformity

Taking Pictures



Analysis points and related data



Item	分析名	检测点名称	系列号	结果	值	Pass/Fail
0	Lateral_Uniformity	检测点名称	SubErvs00	Lr(0)	13.5816	Pass
1	Lateral_Uniformity	检测点名称	SubErvs00	Lr(2)	13.7276	Pass
4	Lateral_Uniformity	检测点名称	SubErvs00	Lr(4)	12.7778	Pass
5	Lateral_Uniformity	检测点名称	SubErvs00	Lr(5)	13.1489	Pass
6	Lateral_Uniformity	检测点名称	SubErvs00	Lr(6)	13.8294	Pass
7	Lateral_Uniformity	检测点名称	SubErvs00	Lr(7)	13.6003	Pass
8	Lateral_Uniformity	检测点名称	SubErvs00	Lr(8)	13.6003	Pass
9	Lateral_Uniformity	检测点名称	SubErvs00	Lr(9)	13.2001	Pass
10	Lateral_Uniformity	检测点名称	SubErvs00	(Lr_max - Lr_min) / Lr_max	7.6178	Pass

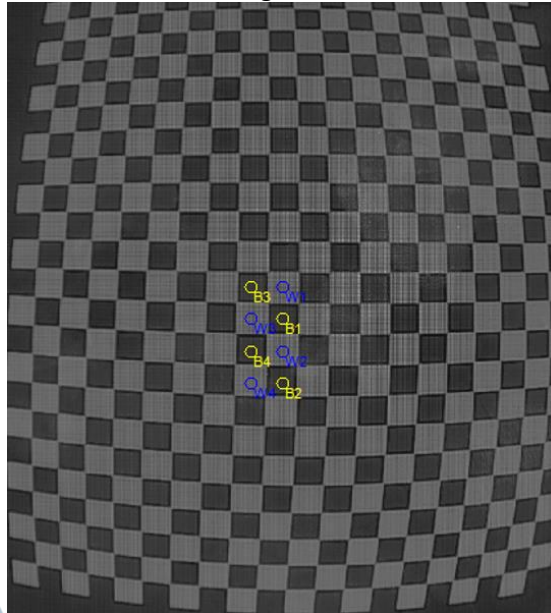
Test result

Item	Standard request	Test Data	Test result
Lateral Uniformity	<35%	7.6178%	PASS

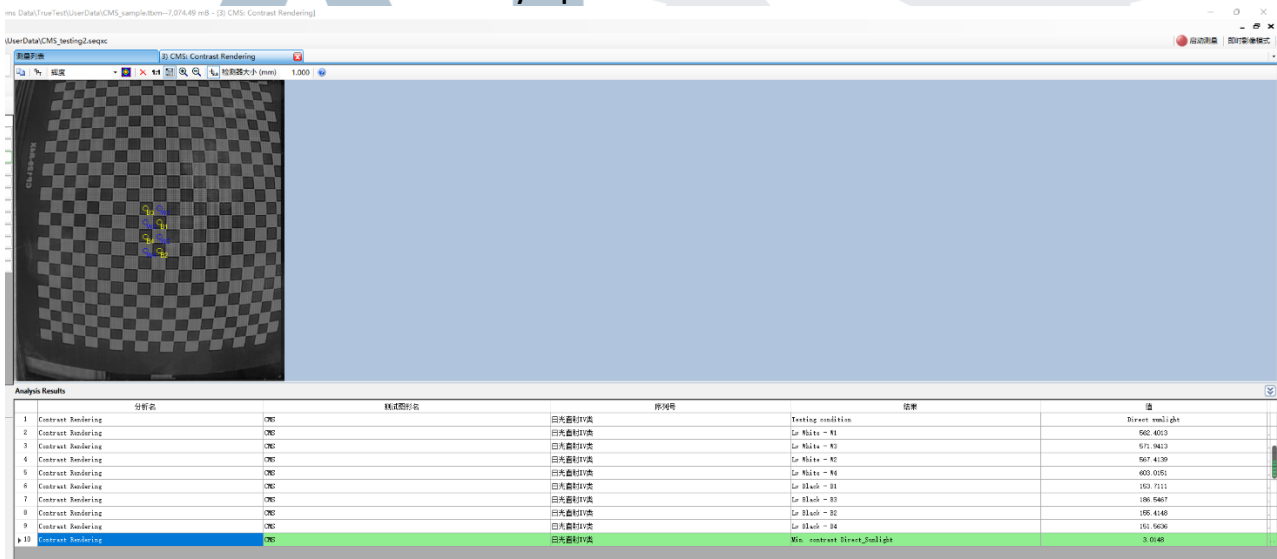
Luminance and contrast rendering

1) For direct sunlight condition

Taking Pictures



Analysis points and related data



Test result

Item	Standard request	Test data	Test result
Maximum brightness contrast	For direct sunlight condition: 2:1	3.0148	PASS

Inspection Report No.: AT5-SM-IR-46-04808



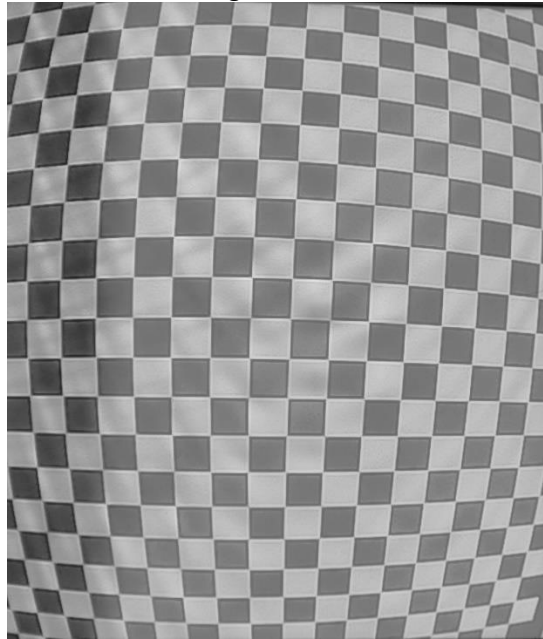
Of: 24/10/2022

Type: RS-RM2511-EU CMS CLASS IV

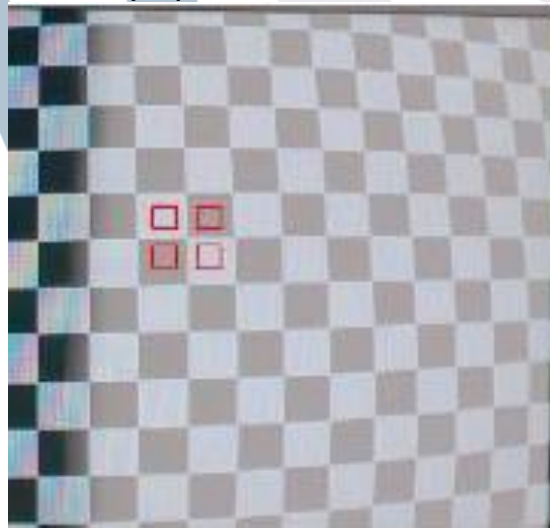
Manufacturer: Guangzhou Rongsheng Technology Co.,Ltd.

2)For day condition

Taking Pictures



Analysis points and related data

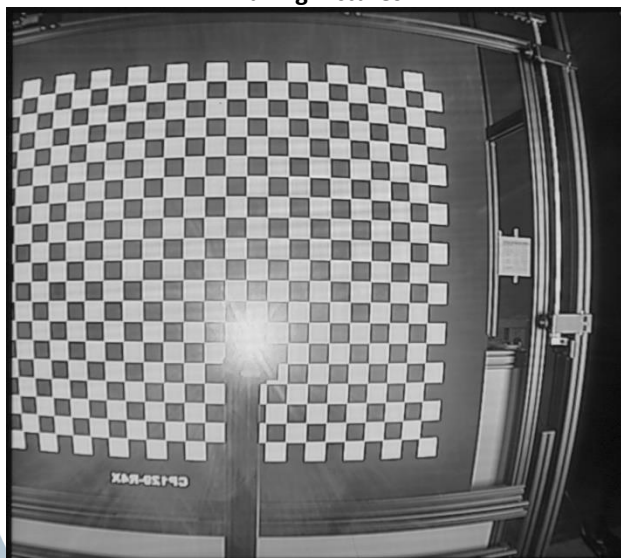


Test result

Item	Standard request	Test result
Maximum brightness contrast	For day condition: 3:1	PASS

3)For sunset condition:

Taking Pictures



Analysis points and related data



Test result

Item	Standard request	Test result
Minimum brightness contrast	For sunset condition: 2:1	PASS

Inspection Report No.: ATS-SM-IR-46-04808



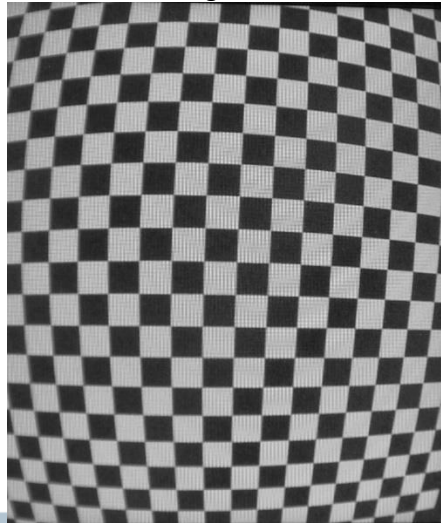
Of: 24/10/2022

Type: RS-RM2511-EU CMS CLASS IV

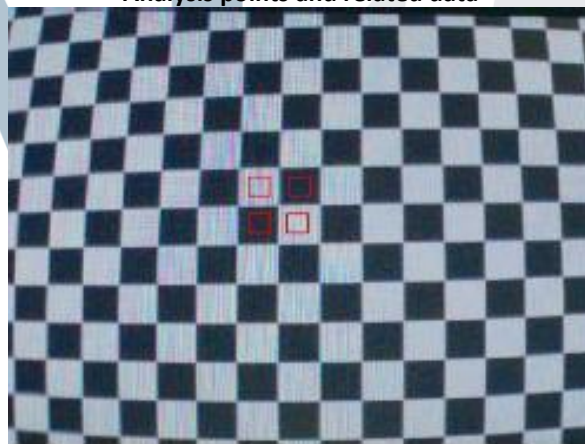
Manufacturer: Guangzhou Rongsheng Technology Co.,Ltd.

4) For night condition

Taking Pictures



Analysis points and related data

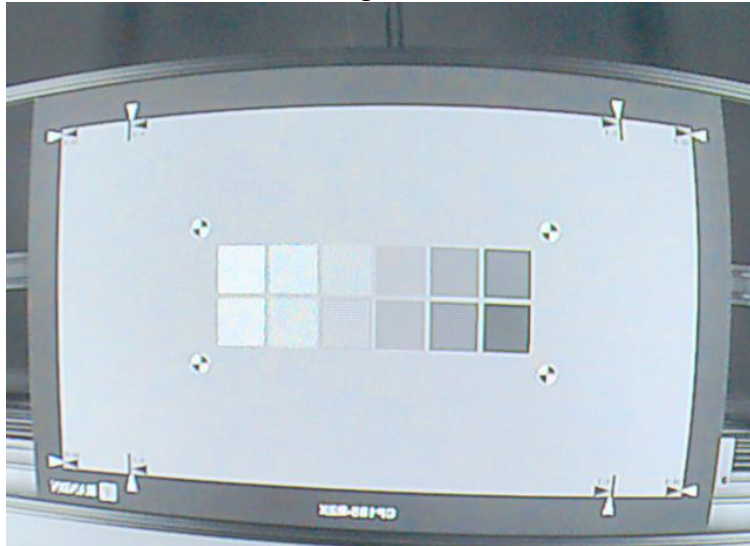


Test result

Item	Standard request	Test data	Test result
Minimum brightness contrast	For night condition: 10:1	16.894655	PASS

Grey scale rendering

Taking Pictures



Analysis points and related data

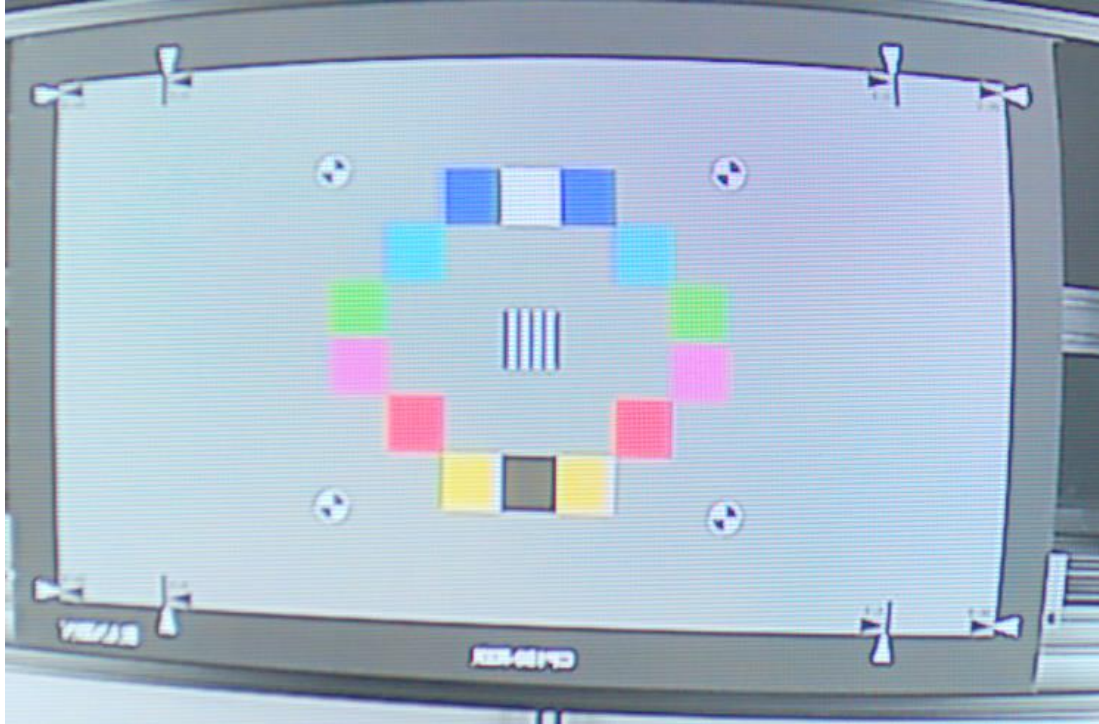


Test result

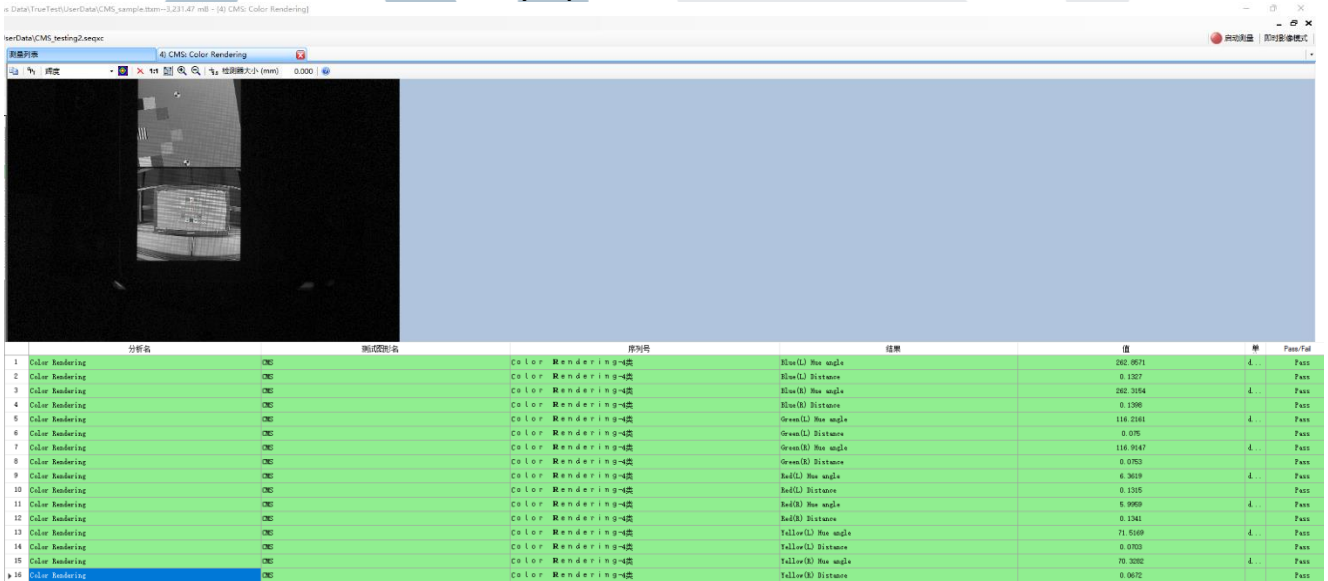
Item	Standard request	Test data	Test result
Grey scale rendering test	Minimum discernible 8	9	PASS

Colour rendering

Taking Pictures



Analysis points and related data



分析名	测试点名称	序列号	结果	值	单	Pass/Fail
1 Color Rendering	CMS	Color Rendering-4类	Blue(L) Hue angle	262.8671	度	Pass
2 Color Rendering	CMS	Color Rendering-4类	Blue(L) Distance	0.1327		Pass
3 Color Rendering	CMS	Color Rendering-4类	Blue(B) Hue angle	282.2084	度	Pass
4 Color Rendering	CMS	Color Rendering-4类	Blue(B) Distance	0.1290		Pass
5 Color Rendering	CMS	Color Rendering-4类	Green(L) Hue angle	114.2141	度	Pass
6 Color Rendering	CMS	Color Rendering-4类	Green(L) Distance	0.076		Pass
7 Color Rendering	CMS	Color Rendering-4类	Green(B) Hue angle	114.9147	度	Pass
8 Color Rendering	CMS	Color Rendering-4类	Green(B) Distance	0.0753		Pass
9 Color Rendering	CMS	Color Rendering-4类	Red(L) Hue angle	6.3619	度	Pass
10 Color Rendering	CMS	Color Rendering-4类	Red(L) Distance	0.1305		Pass
11 Color Rendering	CMS	Color Rendering-4类	Red(B) Hue angle	8.9669	度	Pass
12 Color Rendering	CMS	Color Rendering-4类	Red(B) Distance	0.1241		Pass
13 Color Rendering	CMS	Color Rendering-4类	Yellow(L) Hue angle	71.5169	度	Pass
14 Color Rendering	CMS	Color Rendering-4类	Yellow(L) Distance	0.0703		Pass
15 Color Rendering	CMS	Color Rendering-4类	Yellow(B) Hue angle	70.3082	度	Pass
16 Color Rendering	CMS	Color Rendering-4类	Yellow(B) Distance	0.0672		Pass

Inspection Report No.: ATS-SM-IR-46-04808



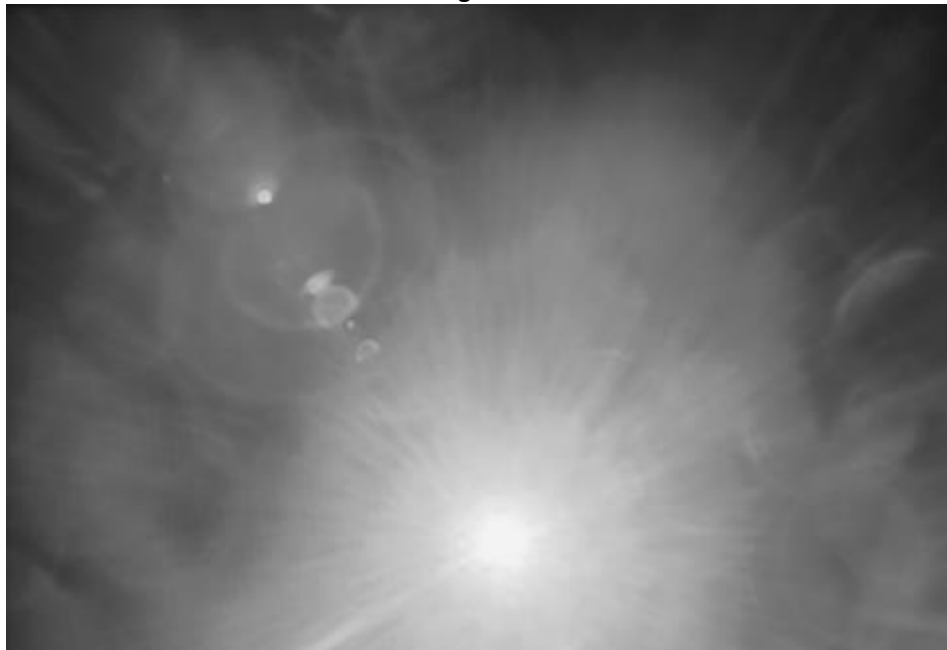
Of: 24/10/2022

Type: RS-RM2511-EU CMS CLASS IV

Manufacturer: Guangzhou Rongsheng Technology Co.,Ltd.

Smear

Taking Pictures



Test result

Item	Standard request	Test data	Test result
Smear	R <10%	0%	PASS

Blooming and lens flare

Taking Pictures



50% brightness region



Test result

Item	Standard request	Test data	Test result
Blooming and lens flare	R <25%	2.08736%	PASS

Inspection Report No.: ATS-SM-IR-46-04808



Of: 24/10/2022

Type: RS-RM2511-EU CMS CLASS IV

Manufacturer: Guangzhou Rongsheng Technology Co.,Ltd.

Frame rate

Taking Pictures of normal illumination

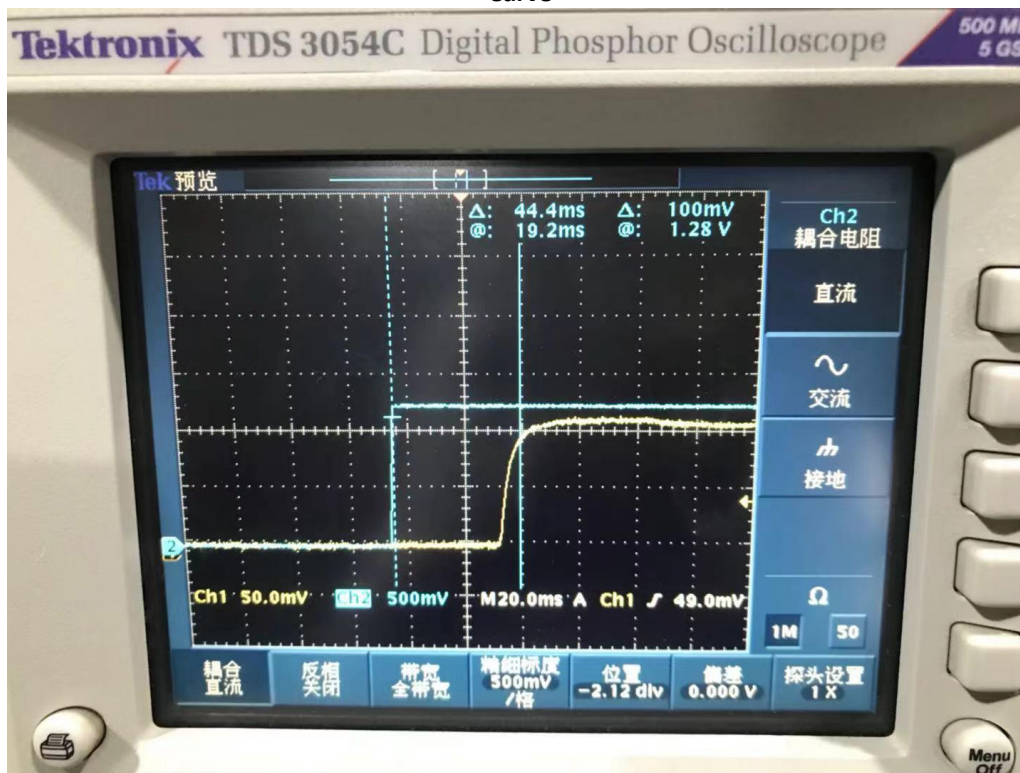


Test result

Item	Standard request	Test data	Test result
Normal illumination	>30Hz	50Hz	PASS
Low Lux	>15Hz	50Hz	PASS

System latency

Curve

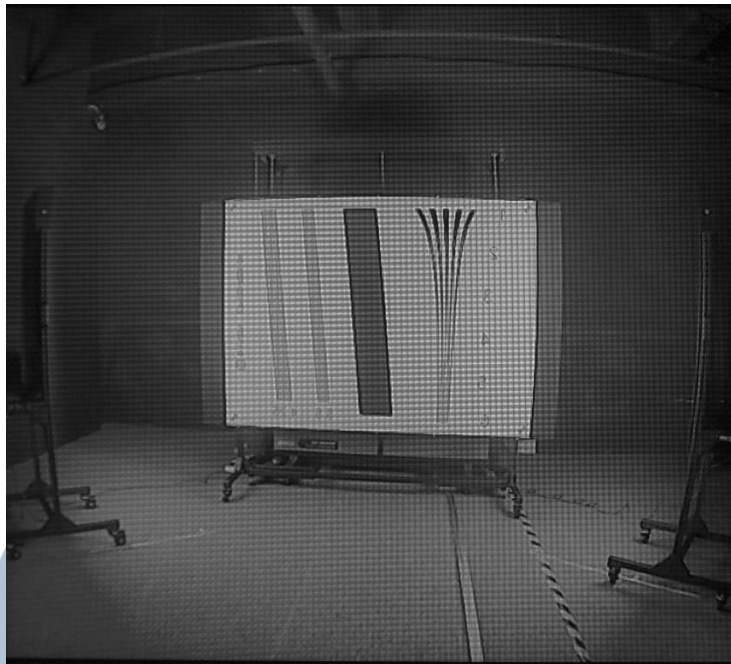


Test result

Item	Standard request	Test data	Test result
System latency	< 200ms	44.4ms	PASS

Depth of field

Taking Pictures-Distance 4m



Inspection Report No.: ATS-SM-IR-46-04808

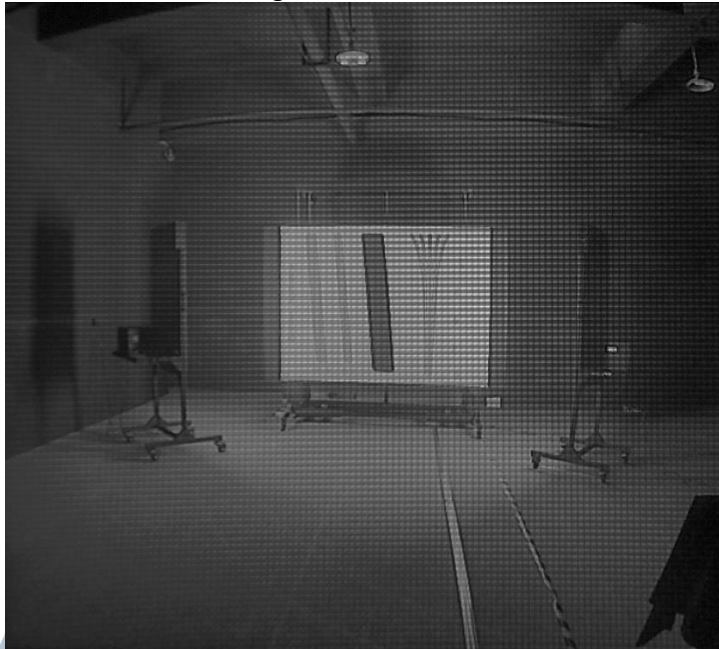


Of: 24/10/2022

Type: RS-RM2511-EU CMS CLASS IV

Manufacturer: Guangzhou Rongsheng Technology Co.,Ltd.

Taking Pictures-Distance 6m



Inspection Report No.: ATS-SM-IR-46-04808



Of: 24/10/2022

Type: RS-RM2511-EU CMS CLASS IV

Manufacturer: Guangzhou Rongsheng Technology Co.,Ltd.

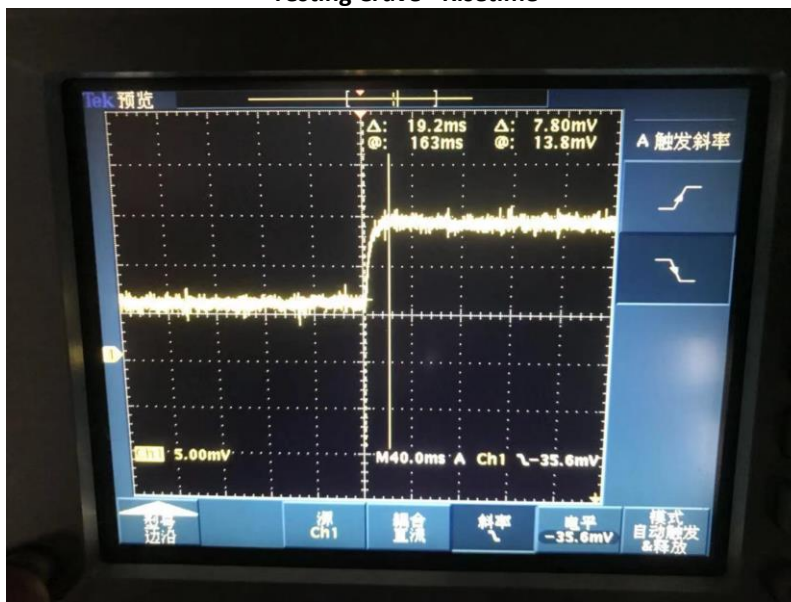
Test result

Item	Test data	Test result
MTF10MIN(1:1)/hor	223.08	PASS
MTF10MIN(1:1)/ver	196.56	PASS
P value of 4m horizontal direction	0.587424	PASS
P value of 4m vertical direction	0.529712	PASS
P value of 6m horizontal direction	0.714821	PASS
P value of 6m vertical direction	0.684439	PASS

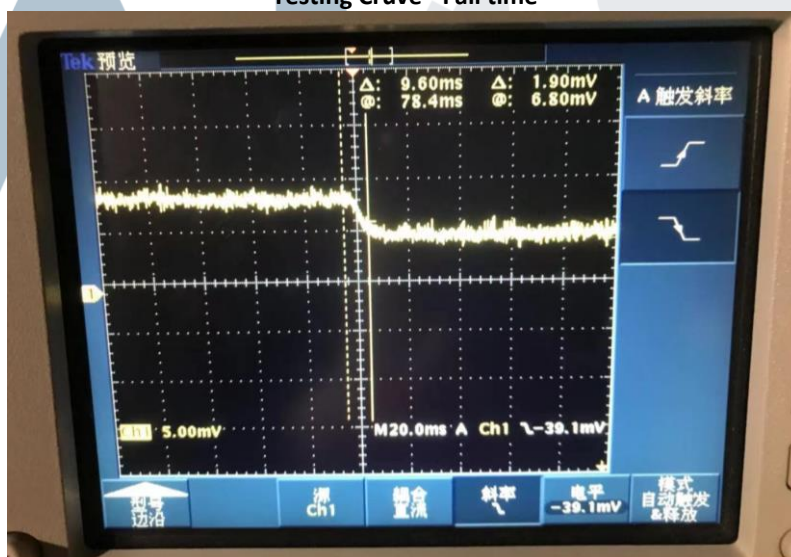


Image formation time

Testing Cruve - Risetime



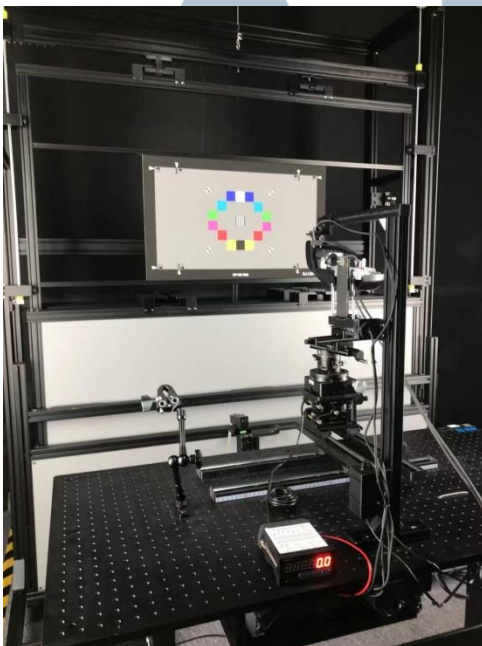
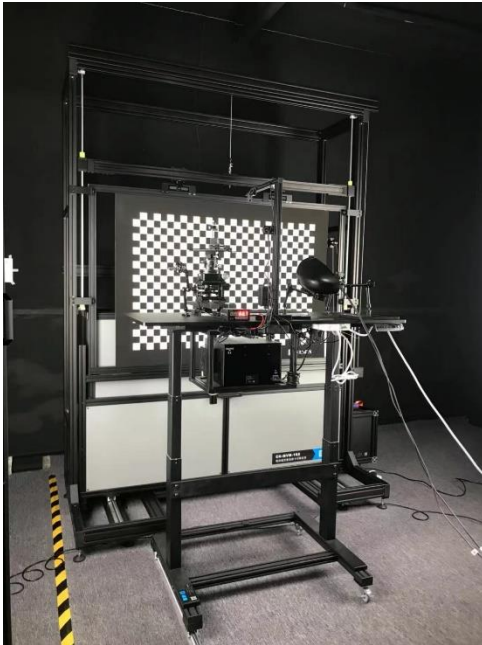
Testing Cruve - Fall time



Test result

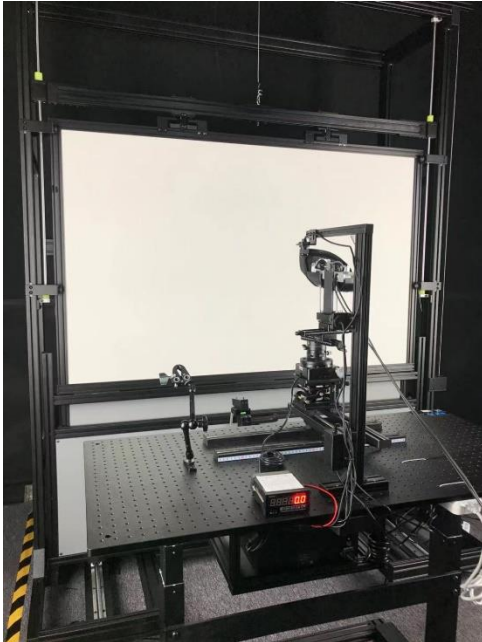
Item	Standard require	Test data	Test result
Risetime	<55ms	19.2ms	PASS
Fall time	<55ms	9.6ms	PASS
Image formation time	<55ms	28.8ms	PASS

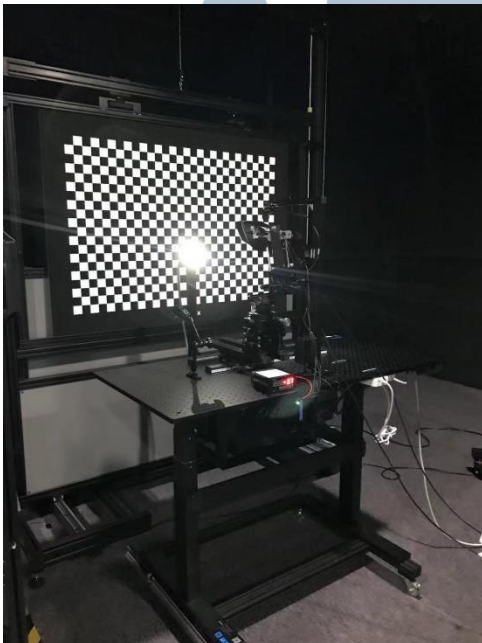
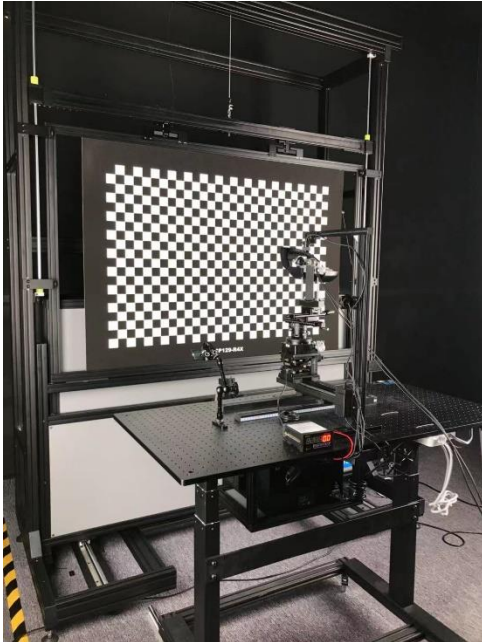
Sample photos

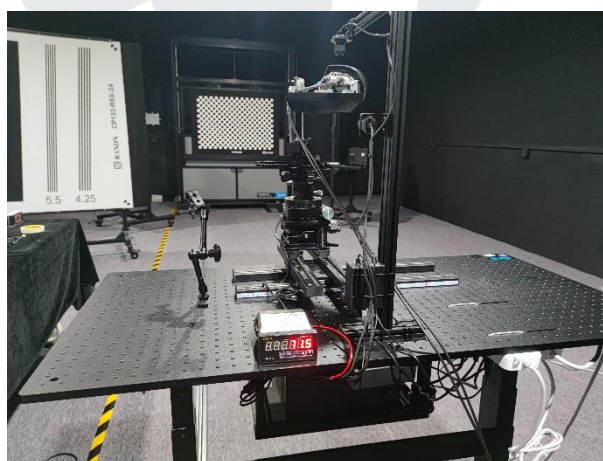
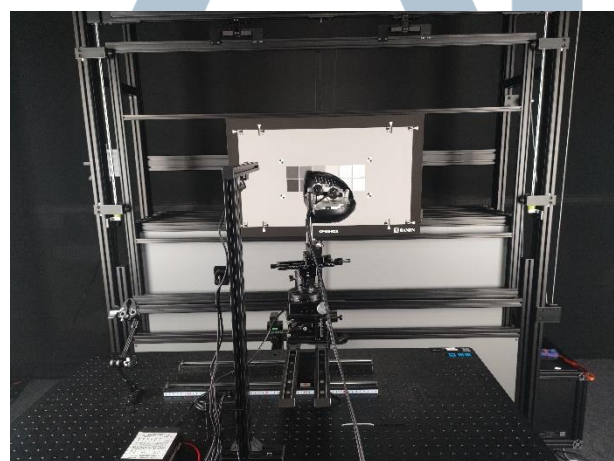
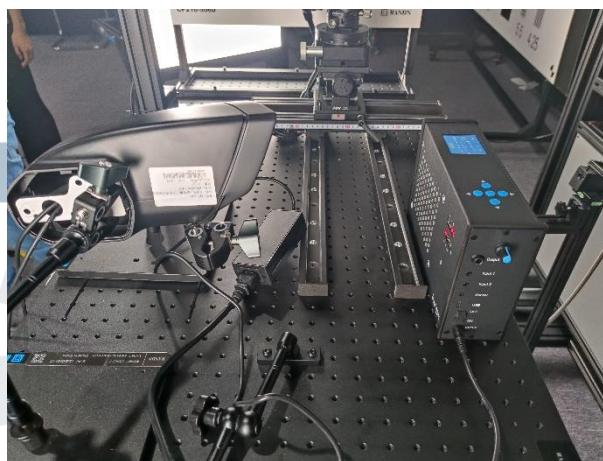
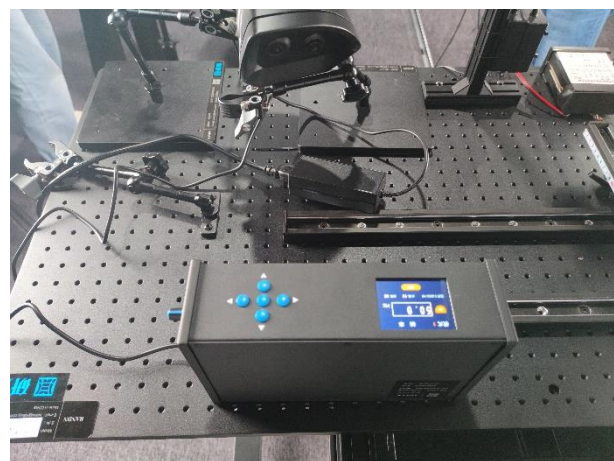
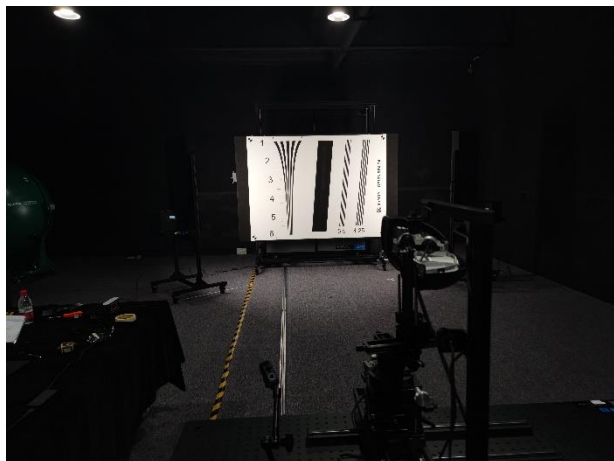


Appendix 3









INFORMATION FOLDER NO. RS-RM2511-EU CMS CLASS IV-00

Manufacturer: Guangzhou Rongsheng Technology Co.,Ltd.

Type: RS-RM2511-EU CMS CLASS IV


Date: 20/09/2022

Responsible name: Xiaokang Zhu

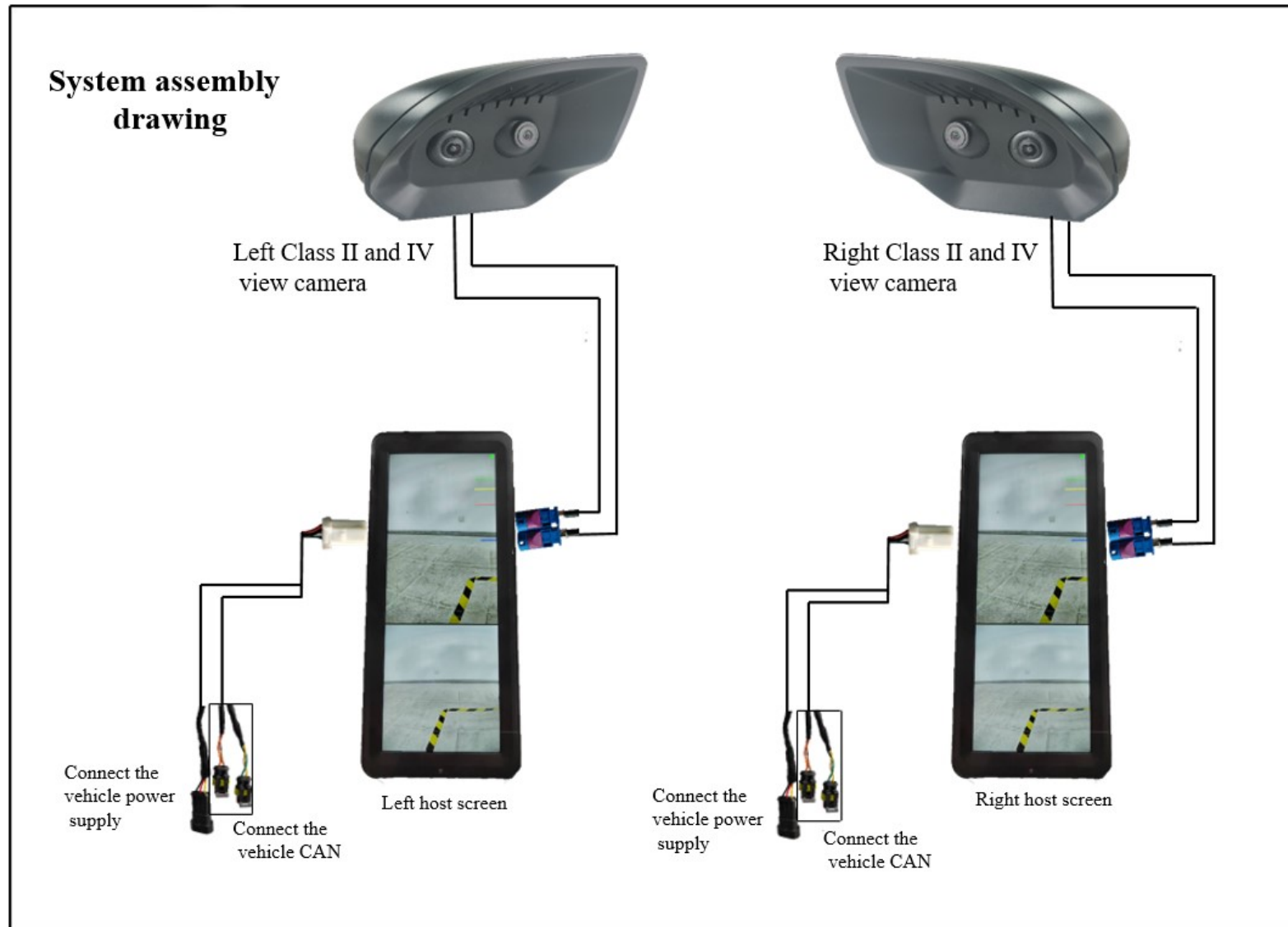


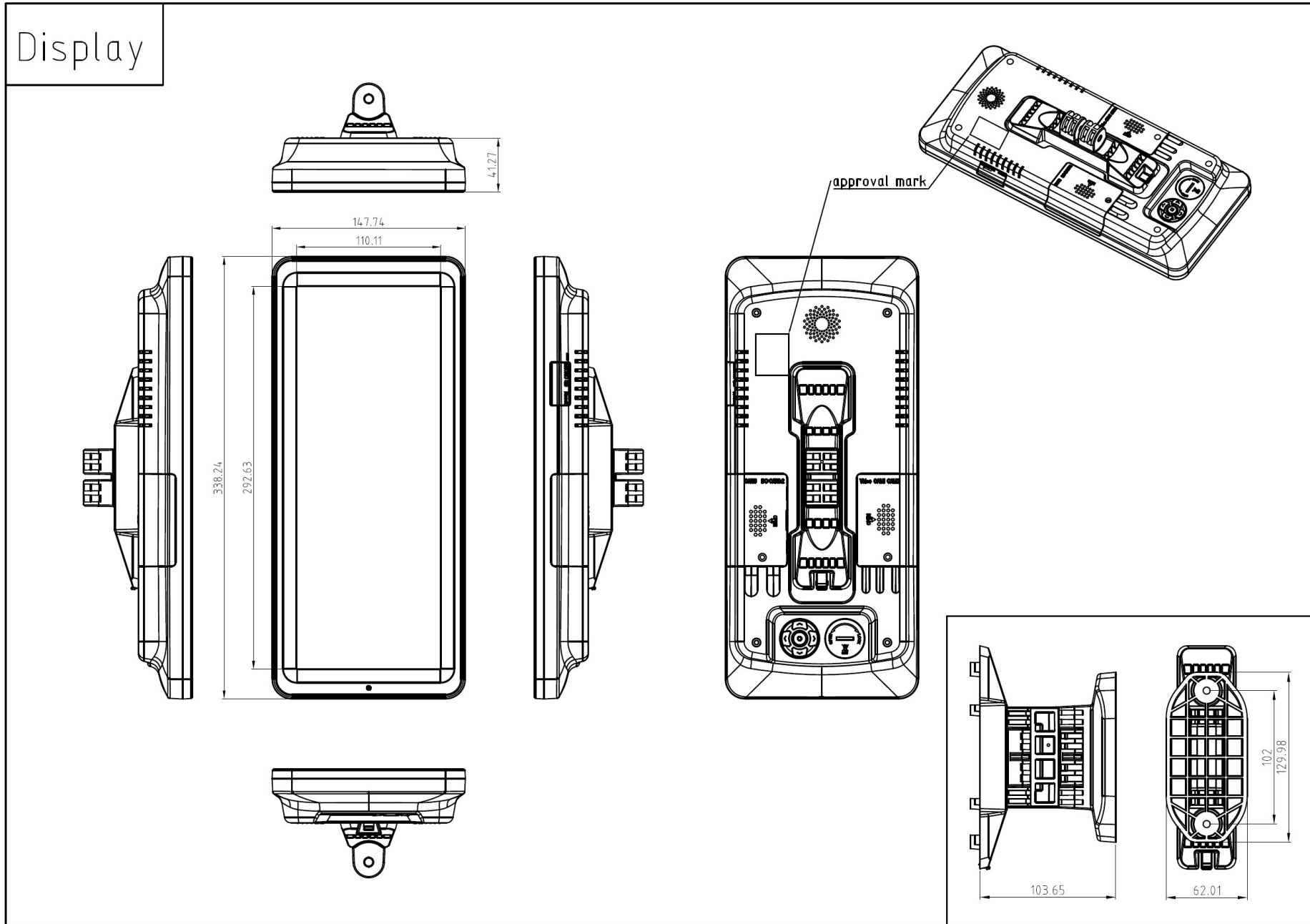
Guangzhou Rongsheng Technology Co.,Ltd.

INFORMATION DOCUMENT
FOR THE TYPE APPROVAL OF REAR-VIEW MIRROR ACCORDING TO
ECE REGULATION 46.05

1. Mark (trade name of manufacturer) :  融盛科技 Rong Sheng (RS)
2. Type and general commercial description(s) : Electronic rearview mirror
Type: RS-RM2511-EU CMS CLASS IV
Variants: RS-RM2511 CMS CLASS IV
3. Means of identification of the type, if indicated on the device : N/A
4. Category of vehicle for which the device is intended : N2,N3,M2,M3
5. Name and address of manufacturer : Guangzhou Rongsheng Technology Co.,Ltd.
4th Floor, G Building, Jiyi Industrial Park, No.
270 Changjiang Road, Panyu District, Guangzhou City, Guangdong Province China 511447.
- 5.1 Address(es) of assembly plant(s) : Same as the manufacturer
6. Name and address of manufacturer's representative : N/A
7. Location and method of affixing of the approval mark : Refer to the drawing
8. Concise description:
- Class : IV
 - General description : Camera Monitor System
Inside of vehicle, take Annex I for details
 - Mounting method : On the column, take Annex I for details
 - Installation angle with respect to : Annex I for details
 - Radius of curvature : Not applicable
 - Main dimensions : Refer to the drawing
 - Monitor housing material : ABS+PC
 - Screen housing material : ABS+PC
9. Remarks (Control system)
- Folding system : NA
 - Reflecting surface adjusting system : Manual

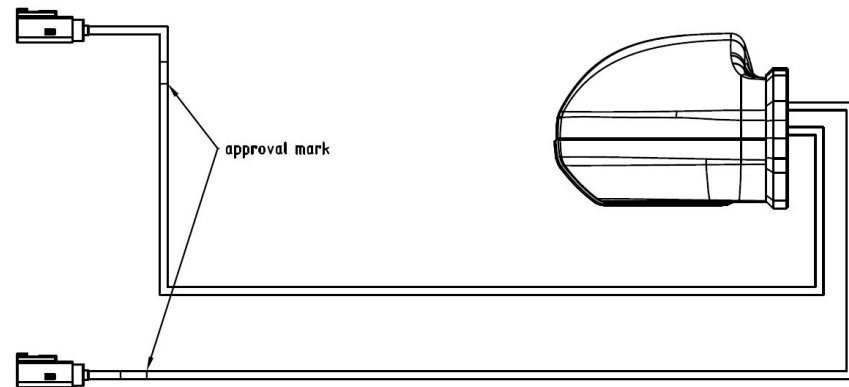
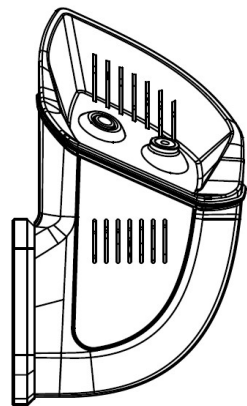
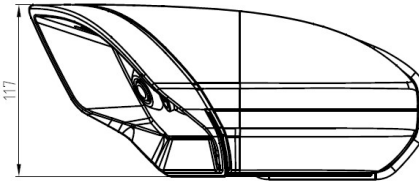
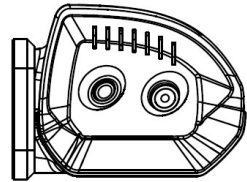
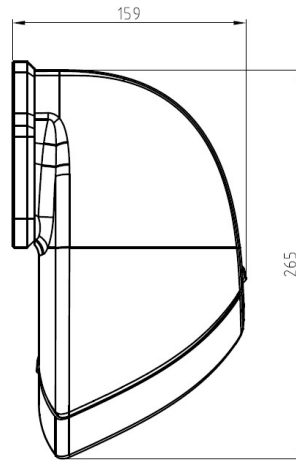
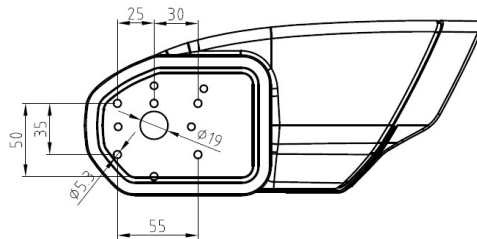
System assembly drawing



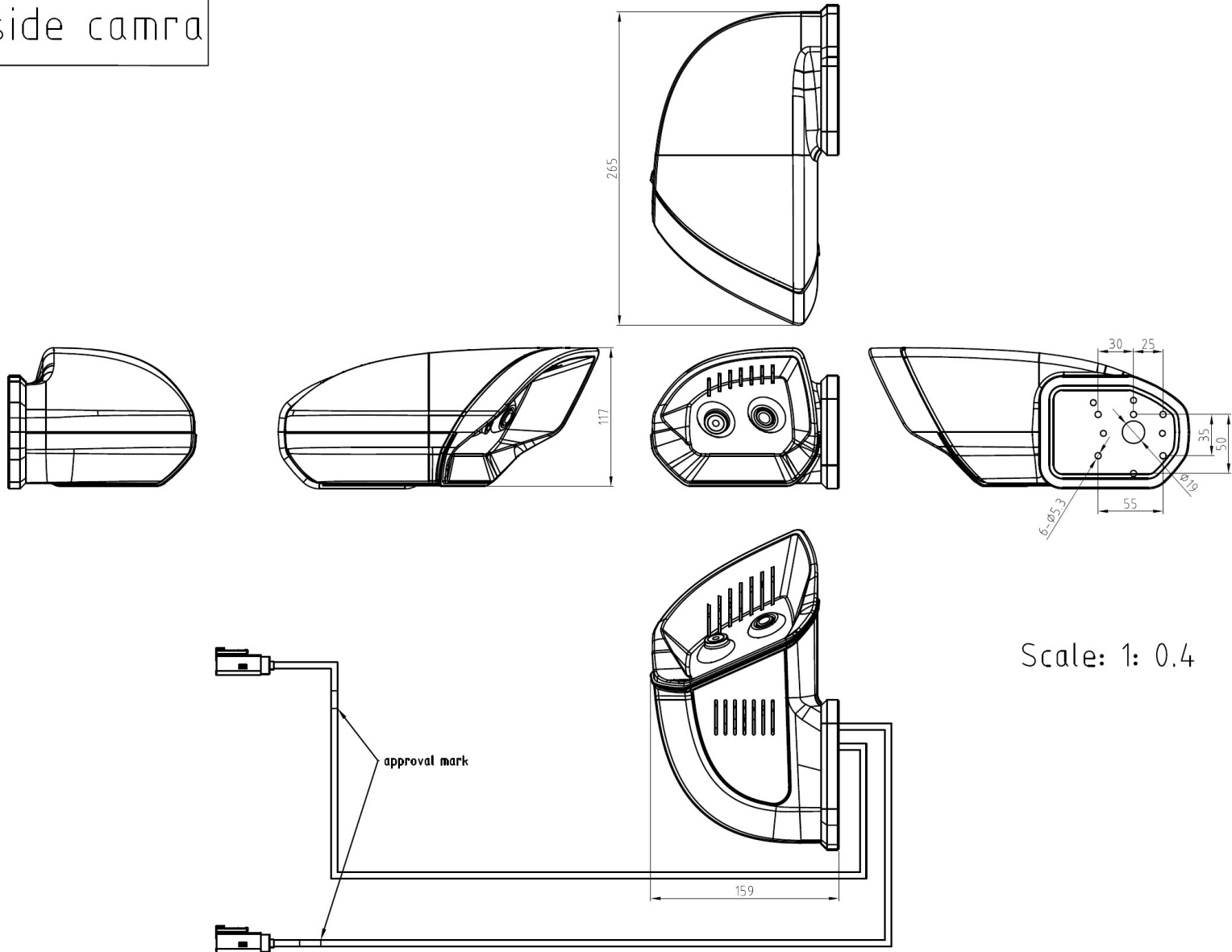


right side camra

Scale: 1: 0.4



left side camra



Scale: 1: 0.4

Annex I

Electronic rearview mirror

Product manual

Guangzhou Rongsheng Technology Co., Ltd.

www.gzrstech.com

No. 270, Changjiang Road, Shilou Town, Panyu District, Guangzhou

RS-RM2511 Product Manual

1 Function introduction

RS-RM2511 is a set of resource rich and powerful system, which is equipped with two camera modules and two sets of displays. The host and display screen are integrated into the host screen, reducing the complexity of the system harness and the difficulty of wiring. This system is designed to replace the traditional Class II and Class IV car rear-view mirrors, and help drivers understand the surrounding environment of the vehicle more clearly by means of sound, image or icon. The RS-RM2511 system complies with UN R46 regulations.

1.1 system description

The function of RS-RM2511 system is to provide drivers with Class II and Class IV visual fields specified by laws and regulations, as shown in Figure 1. In addition, both views are displayed on the same monitor, as shown in Figure 2.

1.2 Class II vision

According to UN R46 regulations, Class II vision is to provide the driver with a rear vision along both sides of the vehicle towards the horizon area, as shown in the upper half of Figure 1.

1.3 Class IV vision

According to UN R46 regulations, Class IV vision is to provide the driver with wide-angle rear vision along both sides of the vehicle towards the horizon area, as shown in the lower half of Figure 1.

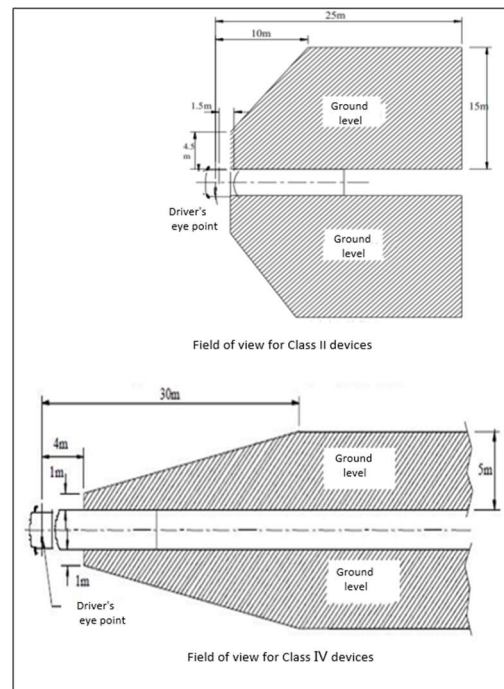


Fig. 1 Class II and IV visual fields

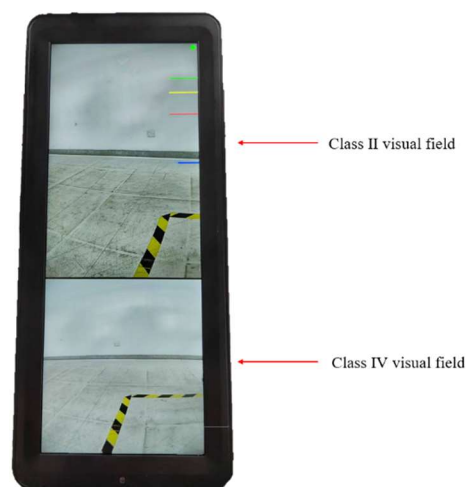


Figure 2 Position of Type II and Type IV visual fields on the display scr

2 RS-RM2511 System Scheme

This product consists of two 12.3-inch screens and four star level digital cameras. The camera has high-definition, large viewing angle, anti glare, wide dynamic, low illumination, high light suppression, and multi-layer coating cameras. It can realize the display of Class II and Class IV visual fields. The display mode can be automatically switched with the vehicle volume and driving status, and can also be automatically or manually triggered according to different driving scenarios.

The electronic rearview mirror camera monitoring system consists of a camera module, a display screen and related harnesses. The system assembly is shown in Figure 3:

- (1) The camera module includes a Class II field of view lens and a Class IV field of view lens. The two cameras adopt different field of view angles, focal lengths and other configurations to meet the needs of different fields of view for images.
- (2) The display screen includes the host (with BSD algorithm), 12.3-inch screen module, key module and horn, which can realize reasonable human-computer interaction when the vehicle is running.
- (3) Relevant harnesses, including coaxial video cable of camera module and system power cable, are highly integrated.

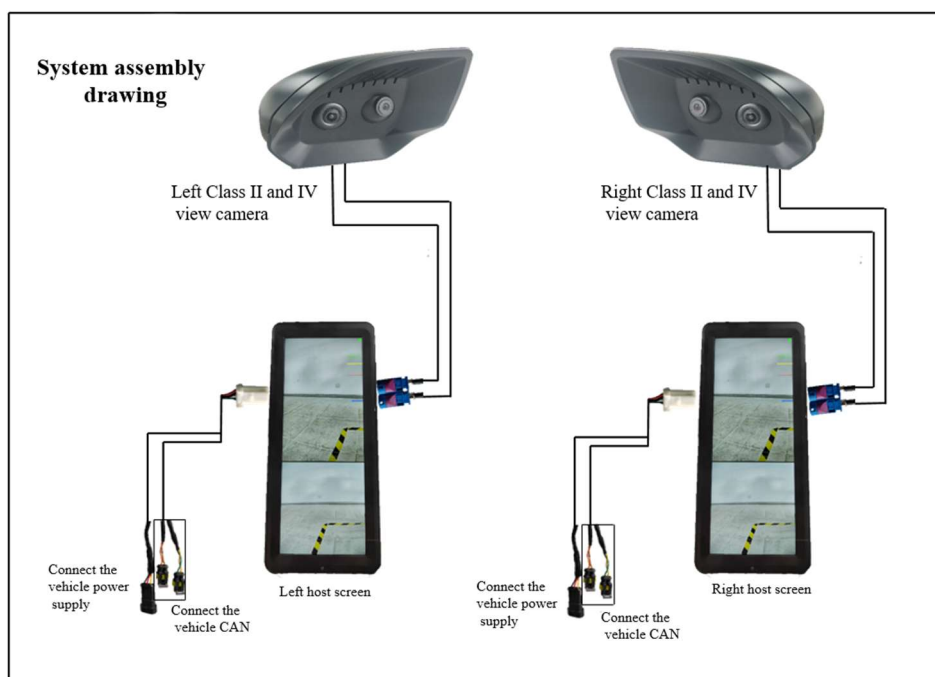


Fig.3 RS-RM2511 System Assembly

3 Installation requirements

The installation position and angle of electronic rear-view mirror system components (such as camera module and host screen) determine the vision acquisition of the system and the driver's visual experience. In UN R46 regulations, there are also requirements for the installation of the electronic rear-view mirror system, so it is necessary to emphasize the correct installation of the display screen, as shown in Figure 4 and Figure 5.

3.1 The left display screen is installed on the first column on the left side of the vehicle. The bottom of the left display screen should be aligned with the bottom of the left exterior mirror as much as possible to avoid blocking the driver's vision. Please adjust it according to the actual situation.

3.2 The right display screen is installed on the first column on the right side of the vehicle, and the right display screen is installed at the same height as the left or slightly raised by 50~100mm.

3.3 The left camera module is installed at the upper left side of the vehicle head, and the right camera module is installed at the upper right side of the vehicle head. The specific installation angle and position need to be set according to the vehicle model and vision requirements.

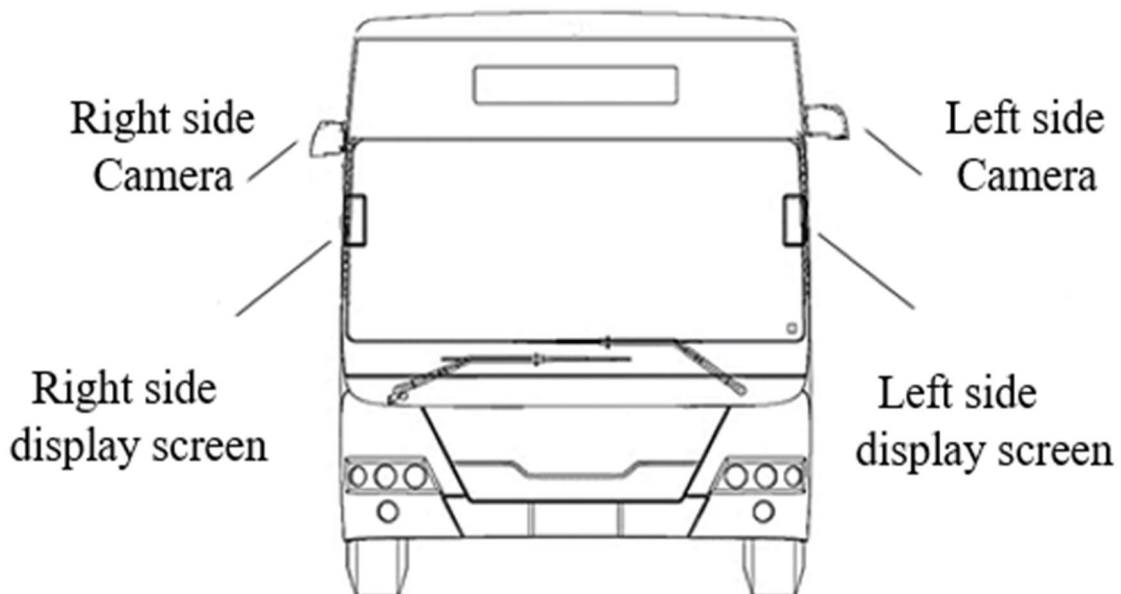


Fig. 4 Schematic diagram of display screen installation position



Fig. 5 Display screen internal installation position

Specific parameter requirements for display screen installation are shown in Table 1 below:

Position	mirror	display size	design Observation horizontal angle	design Observation vertical angle	Eye point distance from display
Driver side	Class II	12.3"	0°	-11°	815mm
	Class IV		0°	11°	800mm
Passenger side	Class II	12.3"	0°	-6°	1225mm
	Class IV		0°	6°	1220mm

Table 1 Description of Display Installation Parameters

4 System overview

4.1 LED status indicator

There is a red LED status indicator behind the 12.3-inch monitor, which will take effect in the following cases:

- Rearview mirror system reset.
- Rear view mirror video stream failure.
- Rear view mirror host screen ECU module failure.
- Rear view mirror system activation fault.

4.2 Start switch

The start switch is used to turn the

electronic rearview mirror system on and off.

When the key is turned off, the system will perform a controlled shutdown. After the startup switch is turned off, the system will remain on for 2 minutes. After these 2 minutes, the system will stand by for another 5 minutes and can be reactivated so that the required field of vision can be obtained again within 1 second. No activation operation (starting the vehicle, opening the front door, etc.) is performed within 7 minutes, and the system shuts down 5 minutes later.

4.3 Display brightness control

Automatic brightness control:according to the surrounding light conditions,the light sensor is used to automatically adjust the brightness of the display to cope with different driving environments.

Manual brightness control:adjust the display brightness through the buttons on the back of the display screen.

4.4 System information storage

In order to meet the requirements of products for higher reliability and lower failure probability,the system needs to be set with certain redundancy.It can realize fault self inspection of all components and modules of the system.At the same time,the images generated during the operation of the electronic rear-view mirror can also be recorded (the SSD is optionally configured). The above information,such as video data and fault information,can also be recorded.Both support local storage through external storage devices.

4.5 Display mode

For different driving scenarios,we have set a variety of vision modes, such as normal

vision mode,temporary vision mode and reverse vision mode. For example,we have designed a temporary vision for vehicles with trailers or with multiple cars turning to ensure that vehicles with multiple cars have enough vision when turning.At the same time,when the vehicle is backing up, the reverse mode will also be triggered to meet the demand for vision around the vehicle when backing up. Special vision modes such as temporary vision and reverse vision can be turned on and off manually.

4.6 Distance line

By default,the distance line is not visible, but you canAccording to the rule call and setting,the distance line can be Driver side monitor and passenger side monitor, as shown in Fig. 6.

The purpose of these distance lines is to determine the distance from other vehicles on the road and to help operators change lanes safely.The driver can calibrate the rear line of the vehicle every time he starts the electronic rearview mirror to automatically set the distance lines A, B and C.



Fig.6 Vehicle Distance Line

5 Specifications and parameters of system components

Camera module and host screen are the main components of the system, and their parameters are shown in the table below.

5.1 Camera parameters

Class II

S/N	Specification	Parameters
1	resolving power	1920*1080/50fps
2	image sensor	1/2.8 inch
3	Pixel Size	2.9um*2.9um
4	aperture	f/No 1.8
5	Wide dynamic range	$\geq 120dB$
6	Minimum illumination	0.1Lux
7	transport protocol	POC
8	Lens form	6G+1R
9	Lens coating	Hydrophobic membrane
10	FOV	Class II: FoV (H) 71°; FoV (V) 40°
11	working temperature	-40°C~+80°C
12	Storage temperature	-40°C~+85°C
13	weight	1006g
14	size	283*158*68mm
15	Degree of protection	IP68

Table2 Camera parameters

Class IV

S/N	Specification	Parameters
1	resolving power	1920*1080/50fps
2	image sensor	1/2.8 inch
3	Pixel Size	2.9um*2.9um
4	aperture	f/No2.0
5	Wide dynamic range	≥120dB
6	Minimum illumination	0.1Lux
7	transport protocol	POC
8	Lens form	4G+2P+1R
9	Lens coating	Hydrophobic membrane
10	FOV	Class IV: FoV (H) 200°; FoV (V) 120°
11	working temperature	-40°C~+80°C
12	Storage temperature	-40°C~+85°C
13	weight	1006g
14	size	283*158*68mm
15	Degree of protection	IP68

Table3 Camera parameters

5.2 screen

S/N	Specification	Parameters
1	Screen Type	IPS TFT a-S
2	Screen resolution	1920*720
3	Screen size	12.3inch
4	color depth	16.7M
5	Screen brightness	1000cd/m2
6	Brightness adjustment	Manual and light sensing automatic
7	transport protocol	POC
8	response time	MAX. 35ms (+25°C)
9	Overall dimensions	338.24*147.74*41.27mm
10	Host kernel	4 Cortex A53 +GPU+VPU
11	operating system	Linux
12	Voltage/current	12V/24V/<2A
13	System Delay	72ms
14	Features	BSD identification and alarm
15	Degree of protection	IP54
16	working temperature	-30°C~+85°C
17	Storage temperature	-40°C~+85°C

Table4 screen parameters

6 System availability

When relevant functions of the electronic rear-view mirror system fail, we set relevant warning signals, such as LED indicator status, green screen prompt, etc. At the same time, we summarized the potential faults of the system and listed the corresponding solutions, as shown in the following table:

Fault	corresponding operation
Black screen	The driver should stop in a safe manner as soon as possible
Green screen	The driver should stop in a safe manner as soon as possible
Overlay menu not available	The driver should evaluate the problem and stop if necessary
Test mode displayed	The driver should stop in a safe manner as soon as possible
mirror image	The driver should stop in a safe manner as soon as possible
Flipped Picture	The driver should stop in a safe manner as soon as possible
Full screen deformation of image	The driver should stop in a safe manner as soon as possible
Some images deform on the screen	The driver should evaluate the problem and stop if necessary
Image color indication error	The driver should evaluate the problem and stop if necessary
Image cropping and scaling are incorrect	The driver should evaluate the problem and stop if necessary
Incorrect image definition	The driver should evaluate the problem and stop if necessary
Image stream is damaged due to electrical failure	The driver should assess the problem and stop the EMI vehicle if necessary
Camera view position error on the monitor	The driver should evaluate the problem and stop if necessary
Image too bright	The driver should evaluate the problem and stop if necessary
Image is too dark	The driver should evaluate the problem and stop if necessary